

**CONO PIENO, MISCELAZIONE INTERNA A SIFONE**  
**FULL CONE, SIPHON INTERNAL MIXING**  
**CONO LLENO, MEZCLA INTERNA POR SUCCIÓN O GRAVEDAD**

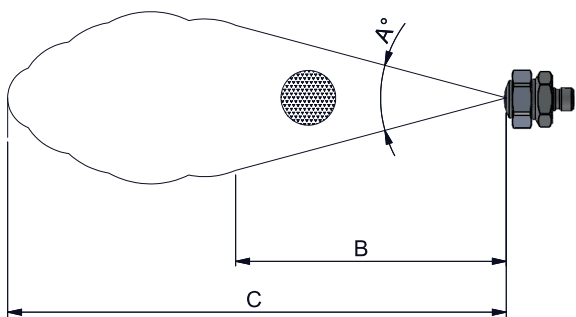
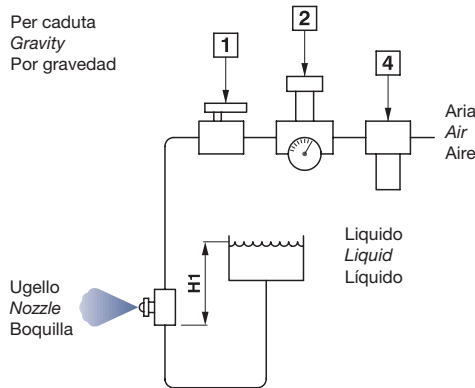
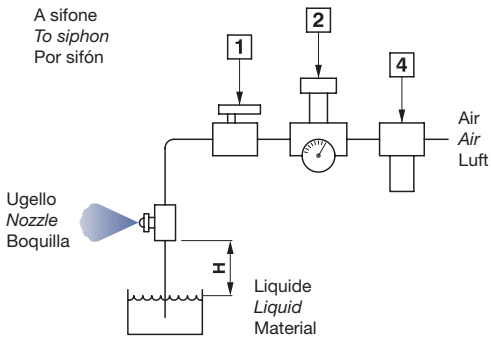

B = distanza entro la quale lo spruzzo rimane costante.  
C = Oltre la distanza C il getto diventa frastagliato.

*B = distance within which the spray remains constant.  
C = Beyond the distance C the jet becomes jagged.*

B = distancia dentro de la cual el spray permanece constante.  
C = Más allá de la distancia C, el chorro se vuelve irregular.



Spray set-up	Atomizing Air		Liquid Capacity (liters per hour)								Spray H = 20 cm			
	Air press. bar	Air Capacity (lpm)	GRAVITY H1			SIPHON H					Air bar	A°	B cm	C m
			45 cm	30 cm	15 cm	10 cm	20 cm	30 cm	60 cm	90 cm				
B1 - S11	0.7	11.3	1.5	1.3	1.1	0.87	0.68	0.53			0.7	18	28	1.8
	1.5	17	1.8	1.7	1.5	1.3	1.2	1.1	0.62		1.5	18	28	1.9
	3.0	28	2.1	1.9	1.7	1.5	1.4	1.3	1.1	0.76	3.0	18	30	2.3
	4.0	36	2.2	2.0	1.8	1.6	1.5	1.4	1.2	0.87	4.0	18	36	2.6
B2 - S11	0.7	13.3	2.4	2.1	1.7	1.5	1.2	0.79			0.7	18	30	2.1
	1.5	20	2.8	2.6	2.4	2.1	1.9	1.6	0.91		1.5	18	33	2.3
	3.0	32	3.4	3.1	2.9	2.8	2.6	2.4	1.7	1.1	3.0	18	38	2.6
	4.0	41	3.7	3.4	3.3	3.1	2.9	2.7	2.1	1.5	4.0	19	43	3.0
B2 - S12	0.7	23	2.5	2.3	2.0	1.6	1.4	1.1			0.7	18	30	2.4
	1.5	36	2.9	2.8	2.5	2.2	2.0	1.7	0.89		1.5	18	33	2.7
	3.0	58	3.4	3.3	3.2	2.9	2.8	2.5	1.9	1.2	3.0	19	38	3.4
	4.0	74	3.7	3.6	3.5	3.4	3.3	3.0	2.5	2.0	4.0	20	43	4.0
B3 - S12	0.7	19.3	4.5	4.0	3.4	2.1	1.8	1.4			0.7	21	38	3.0
	1.5	31	5.3	4.9	4.4	3.5	2.9	2.7	1.8		1.5	21	41	3.4
	3.0	50	6.0	5.6	5.0	4.4	4.0	3.4	2.4	1.2	3.0	21	46	4.0
	4.0	65	5.7	5.4	5.0	4.2	3.9	3.5	2.8	1.9	4.0	22	51	4.6
B6 - S14	1.5	58	22	19.9	16.3	12.3	10.5	8.3	2.8		1.5	17	46	3.7
	3.0	88	25	23	19.5	16.7	14.2	11.5	6.4	2.8	3.0	18	51	4.3
	4.0	111	26	24	21	18.4	15.7	12.9	7.9	4.5	4.0	18	53	4.9
	5.6	147	26	24	22	19.7	17.0	14.6	9.8	6.1	5.6	19	58	5.5
B8 - S15	1.5	144				27	22	16.5			2.0	20	51	6.7
	3.0	190				30	26	21			3.0	20	53	7.0
	4.0	240		43	40	31	28	23	11.0		4.0	21	58	7.6
	5.6	315	44	42	39	31	28	24	16.7	8.3	5.6	22	63	8.2