

Rotoflux in acciaio inox
Rotoflux stainless steel unions
Rotoflux Edelstahl
Rotoflux de acero inoxidable
 $\frac{1}{4}'' \div 2''$

		$^{\circ}\text{C}$ / $^{\circ}\text{F}$	$\frac{\text{G}}{\text{m}^2}$ / RPM
Acqua - Water - Wasser - Agua	$1/4'' \div 1 1/2'' \triangleright 50 \text{ bar} / 725 \text{ PSI}$ $2'' \triangleright 40 \text{ bar} / 580 \text{ PSI}$	95°C / 203°F	$1/4'' \div 3/4'' \triangleright 3.500$
Aria - Air - Luft - Aire	10 bar / 145 PSI		1" \triangleright 3.000
Vuoto - Vacuum - Vakuum - Vacio	7 kPa / 2" Hg		$1 1/4'' \div 1 1/2'' \triangleright 2.500$ 2" \triangleright 750

IT ROTOFLEX IN ACCIAIO INOX

I giunti della serie F sono disponibili con due tipi di tenute meccaniche bilanciate-microlappate:

- Tenute N (Tenute Normali) in grafite contro carburo.
- Tenute D (Tenute Dure) in carburo contro carburo.

Tutti particolari metallici in contatto con il fluido sono in acciaio inox. Per rotazioni sia destrorse che sinistrorse utilizzare la versione con albero a flangia. Non utilizzare i giunti alle massime condizioni di esercizio senza consultare ROTOFLEX.

UK ROTOFLEX STAINLESS STEEL UNIONS

The unions of the model F, in stainless steel, are provided with two different micro-lapped sealing assemblies:

- N model (Standard) with carbon graphite to carbide seals.
- D model (Heavy duty) with carbide to carbide seals.

All the metallic parts in contact with the fluid, are in stainless steel. Flange rotor are available for rotations in both directions. Do not use the unions at max application limits without consulting ROTOFLEX.

DE ROTOFLEX EDELSTAHL

Diese Drehdurchführungen der Serie F sind verfügbar mit zwei unterschiedlichen ausgeglichenen, feinstgeläppten mechanischen Dichtungen:

- N-Dichtungen (Normale Ausführungen) aus Kohlegraphit gegen Karbid.
- D- Dichtungen (Für hohe Beanspruchungen) aus Karbid gegen Karbid.

Alle mit dem Medium in Berührung kommenden Metallteile sind aus rostfreiem Stahl hergestellt. Die Drehdurchführungen dieses Modells sind mit Gewinde und Flanschanschluss lieferbar. Die Dredurchführungen nicht unter den maximalen Betriebsbedingungen verwenden, ohne sich vorher mit dem ROTOFLEX Kundendienst abgesprochen zu haben.

E ROTOFLEX DE ACERO INOXIDABLE

Las juntas rotativas de la serie F, en acero inoxidable, están disponibles con dos versiones de sellos equilibrados y lapeados:

- Sello N (Sello estándar) de grafito contra carburo.
- Sello D (Sello duro) de carburo contra carburo.

Todas las partes metálicas en contacto con el fluido son de acero inoxidable. Par a aplicaciones con rotaciones tanto horarias como anti-horarias aconsejamos las juntas con montaje embridado. En el caso de la aplicación esté al limite de las características técnicas, les rogamos se pongan en contacto el departamento técnico de ROTOFLEX.

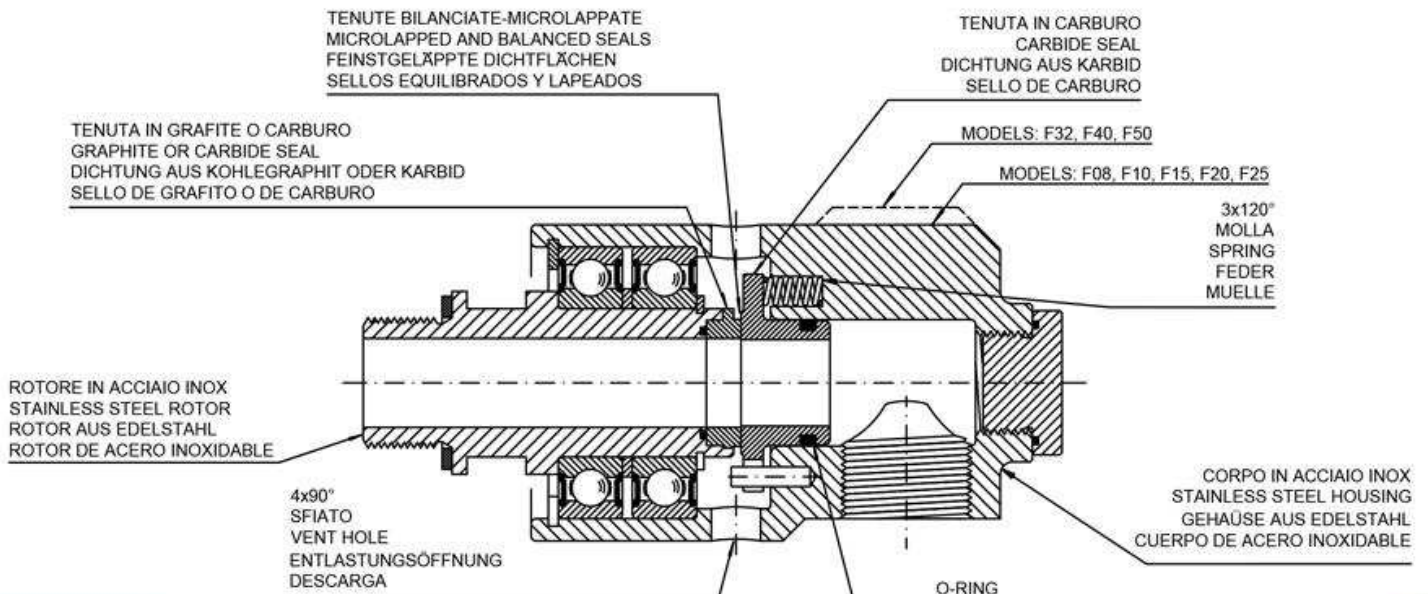

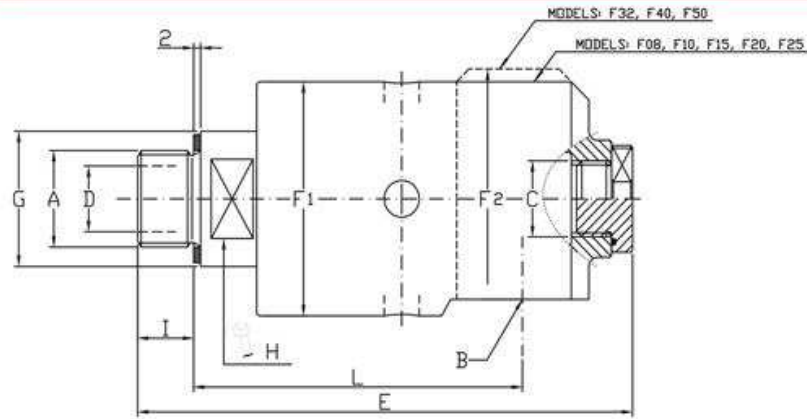

Ordering code			Giunti a un passaggio - Single passage unions Einweg Drehdurchführungen - Juntas a via simple											
Water N	Water D	Air - Vacuum	A	B	C	ø D	E	ø F1	ø F2	ø G	H	I	L	Kg
F08-1300-01R	F08-1301-01R	F08-1302-01R	G 1/4" RH	G 1/4"	-	7	88	43	-	20	17	11	67	0,6
F08-1300-02L	F08-1301-02L	F08-1302-02L	G 1/4" LH											
F10-1300-01R	F10-1301-01R	F10-1302-01R	G 3/8" RH	G 3/8"	G 1/4"	9	108	43	-	25	17	13	73	0,7
F10-1300-02L	F10-1301-02L	F10-1302-02L	G 3/8" LH											
F15-1300-01R	F15-1301-01R	F15-1302-01R	G 1/2" RH	G 1/2"	G 3/8"	13	121	54	-	30	24	13	82	1,3
F15-1300-02L	F15-1301-02L	F15-1302-02L	G 1/2" LH											
F20-1300-01R	F20-1301-01R	F20-1302-01R	G 3/4" RH	G 3/4"	G 1/2"	18	142	64	-	37	30	16	94	1,9
F20-1300-02L	F20-1301-02L	F20-1302-02L	G 3/4" LH											
F25-1300-01R	F25-1301-01R	F25-1302-01R	G 1" RH	G 1"	G 3/4"	23	166	69	-	45	36	20	105	2,4
F25-1300-02L	F25-1301-02L	F25-1302-02L	G 1" LH											
F32-1300-01R	F32-1301-01R	F32-1302-01R	G 1 1/4" RH	G 1 1/4"	G 1"	31	187	85	95	55	46	22	119	4,7
F32-1300-02L	F32-1301-02L	F32-1302-02L	G 1 1/4" LH											
F40-1300-01R	F40-1301-01R	F40-1302-01R	G 1 1/2" RH	G 1 1/2"	G 1 1/4"	36	209	101	109	60	50	24	132	7
F40-1300-02L	F40-1301-02L	F40-1302-02L	G 1 1/2" LH											
F50-1300-01R	F50-1301-01R	F50-1302-01R	G 2" RH	G 2"	G 1 1/4"	48	224	112	119	70	60	25	139	8,2
F50-1300-02L	F50-1301-02L	F50-1302-02L	G 2" LH											

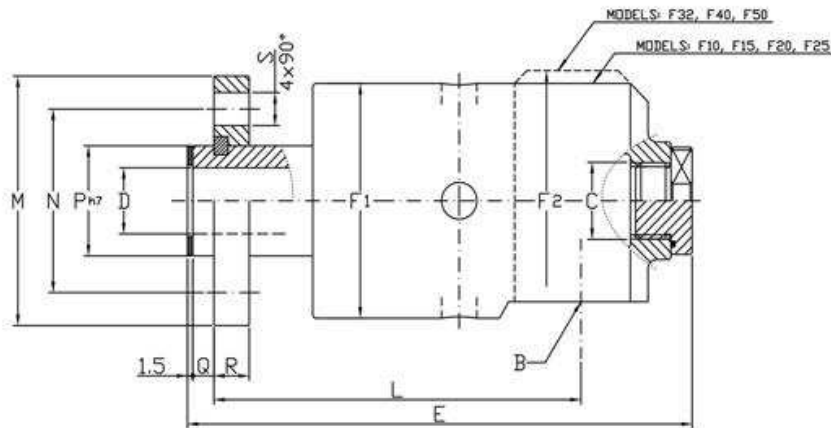

Ordering code			Giunti a un passaggio - Single passage unions Einweg Drehdurchführungen - Juntas a via simple													
Water N	Water D	Air - Vacuum	B	C	ø D	E	ø F1	ø F2	L	ø M	ø N	ø P h7	Q	R	S	Kg
F10-1300-03F	F10-1301-03F	F10-1302-03F	G 3/8"	G 1/4"	9	111	43	-	82	53	38	18	6	8	9	0,8
F15-1300-03F	F15-1301-03F	F15-1302-03F	G 1/2"	G 3/8"	13	125	54	-	92	60	45	25	6	10	9	1,5
F20-1300-03F	F20-1301-03F	F20-1302-03F	G 3/4"	G 1/2"	18	140	64	-	101	68	50	30	6	10	9	2,1
F25-1300-03F	F25-1301-03F	F25-1302-03F	G 1"	G 3/4"	23	168	69	-	119	78	60	36	7	12	9	2,7
F32-1300-03F	F32-1301-03F	F32-1302-03F	G 1 1/4"	G 1"	31	189	85	95	133	94	70	44	8	12	11	5,3
F40-1300-03F	F40-1301-03F	F40-1302-03F	G 1 1/2"	G 1 1/4"	36	204	101	109	139	99	78	52	10	14	11	7,2
F50-1300-03F	F50-1301-03F	F50-1302-03F	G 2"	G 1 1/4"	48	225	112	119	154	119	95	65	10	14	11	9

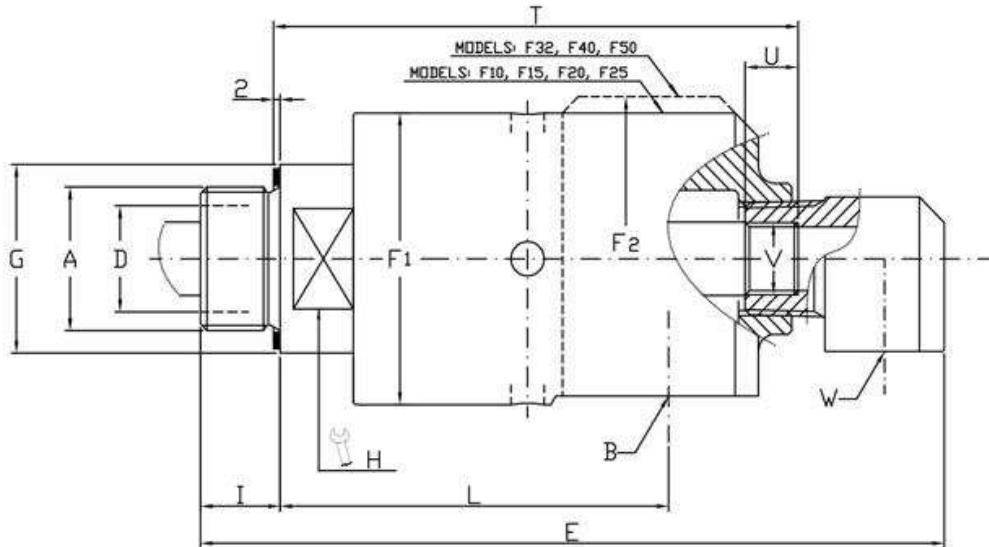

Ordering code		Giunti due passaggi sifone fisso - Double passage stationary siphon Zweige für stehendes Siphonrohr - Double vía con sifón fijo														
Water D	Water N	A	B	ø D	E	ø F1	ø F2	ø G	H	I	L	T	U	V	W	Kg
F10-1300-01R-800	F10-1301-01R-800	G 3/8" RH	G 3/8"	9	129	43	-	25	17	13	73	92	10	M6	G 1/4"	0,9
F10-1300-02L-800	F10-1301-02L-800	G 3/8" LH														
F15-1300-01R-800	F15-1301-01R-800	G 1/2" RH	G 1/2"	13	146	54	-	30	24	13	82	105	12	G 1/8"	G 3/8"	1,5
F15-1300-02L-800	F15-1301-02L-800	G 1/2" LH														
F20-1300-01R-800	F20-1301-01R-800	G 3/4" RH	G 3/4"	18	173	64	-	37	30	16	94	123	14	G 1/4"	G 1/2"	2,2
F20-1300-02L-800	F20-1301-02L-800	G 3/4" LH														
F25-1300-01R-800	F25-1301-01R-800	G 1" RH	G 1"	23	200	69	-	45	36	20	105	144	16	G 3/8"	G 1/2"	2,7
F25-1300-02L-800	F25-1301-02L-800	G 1" LH														
F32-1300-01R-800	F32-1301-01R-800	G 1 1/4" RH	G 1 1/4"	31	224	85	94	55	46	22	119	158	16	G 1/2"	G 3/4"	5,1
F32-1300-02L-800	F32-1301-02L-800	G 1 1/4" LH														
F40-1300-01R-800	F40-1301-01R-800	G 1 1/2" RH	G 1 1/2"	36	256	93	109	60	50	24	132	177	18	G 3/4"	G 1"	7,4
F40-1300-02L-800	F40-1301-02L-800	G 1 1/2" LH														
F50-1300-01R-800	F50-1301-01R-800	G 2" RH	G 2"	48	281	112	119	70	60	25	139	193	20	G 1"	G 1 1/4"	8,7
F50-1300-02L-800	F50-1301-02L-800	G 2" LH														

Sono disponibili filettature Metriche, NPT ed altre
 Metric threads , NPT threads and other threads are available
 Verfügbar sind metrische, NPT und andere Gewindeformen.
 Disponibles rosca métrica, NPT y otras, según necesidad.

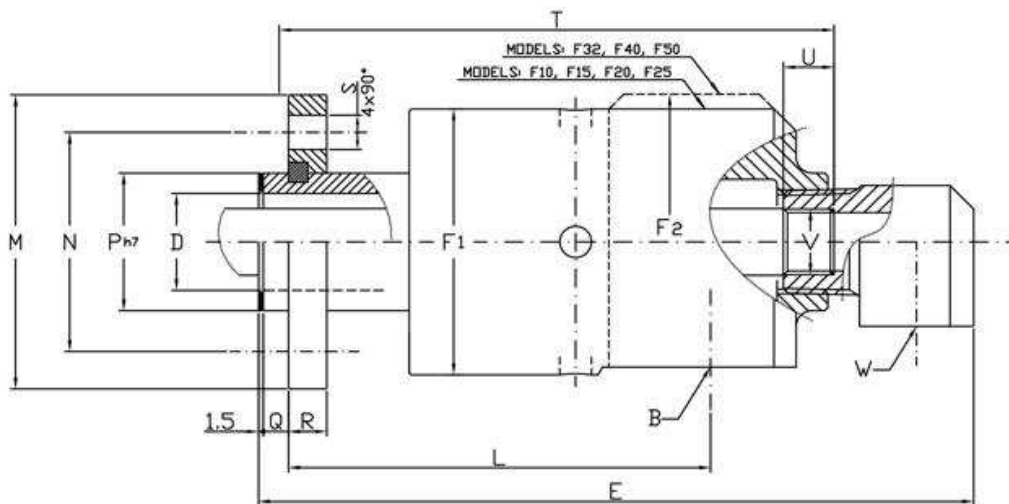

Ordering code		Giunti due passaggi sifone fisso - Double passage stationary siphon Zweige für stehendes Siphonrohr - Double vía con sifón fijo																
Water N	Water D	B	ø D	E	ø F1	ø F2	L	ø M	ø N	ø P h7	Q	R	S	T	U	V	W	Kg
F10-1300-03F-800	F10-1301-03F-800	G 3/8"	9	132	43	-	82	53	38	18	6	8	9	101	10	M6	G 1/4"	1
F15-1300-03F-800	F15-1301-03F-800	G 1/2"	13	151	54	-	92	60	45	25	6	10	9	115	12	G 1/8"	G 3/8"	1,7
F20-1300-03F-800	F20-1301-03F-800	G 3/4"	18	172	64	-	101	68	50	30	6	10	9	130	14	G 1/4"	G 1/2"	2,4
F25-1300-03F-800	F25-1301-03F-800	G 1"	23	202	69	-	119	78	60	36	7	12	9	157	16	G 3/8"	G 1/2"	3
F32-1300-03F-800	F32-1301-03F-800	G 1 1/4"	31	225	85	94	133	94	70	44	8	12	11	172	16	G 1/2"	G 3/4"	5,6
F40-1300-03F-800	F40-1301-03F-800	G 1 1/2"	36	251	93	109	139	99	78	52	10	14	11	185	18	G 3/4"	G 1"	7,6
F50-1300-03F-800	F50-1301-03F-800	G 2"	48	282	112	119	154	119	95	65	10	14	11	208	20	G 1"	G 1 1/4"	9,5

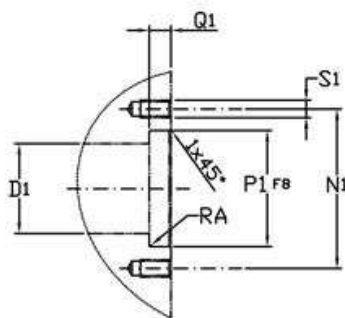

Interfaccia cliente - Customer interface Montageanweisungen - Montaje de la junta						
	ø D1	ø N1	ø P1 F8	RA	Q1	S1
F10	9	38	18	0,2	6	M8 4x90°
F15	13	45	25	0,2	6	M8 4x90°
F20	18	50	30	0,2	6	M8 4x90°
F25	23	60	36	0,2	7	M8 4x90°
F32	31	70	44	0,2	8	M10 4x90°
F40	36	78	52	0,2	10	M10 4x90°
F50	48	95	65	0,2	10	M10 4x90°