



Rotoflux per macchine da stampa

Rotoflux for printing machines

Rotoflux für Druckmaschinen

Rotoflux para maquinas de impresión

3/8" ÷ 1/2"



Acqua / Water / Wasser / Agua	50 bar / 725 PSI	95°C / 203°F	3.500/5.000/7.000

I Rotoflux per macchine da stampa

Questi giunti sono disponibili con due tipi di tenute meccaniche bilanciate-microlappate :

- Tenute N (Tenute Normali) in grafite contro carburo per applicazioni con acqua filtrata.

Pressioni sopra 8 bar sono ammesse solo con acqua ad una temperatura max. di 50°C. Non utilizzare i giunti alle massime condizioni di esercizio senza consultare ROTOFLUX.

UK Rotoflux for printing machines

These unions are available with two different balanced and microlapped sealing assemblies :

- N Seal (Standard Sealing) with carbon graphite to carbide seals for application with filtered water.

Fluid pressure over 8 bar is allowed only when the fluid is cool water at max temperature 125°F (50°C). Do not use the unions at max application limits without consulting ROTOFLUX.

DE Rotoflux für Druckmaschinen

Mit zwei unterschiedlichen, feinstgeläpften Dichtungen lieferbar :

- N-Dichtungen (normale Ausführungen) aus Kohlegraphit gegen Karbid, für Anwendungen mit gefiltertem Wasser.

Mediendrucke über 8 bar sind nur für Anwendungen mit kaltem Wasser bis zu Temperatur von 50°C zulässig. Die Drehdurchführungen dürfen nicht unter den maximalen Betriebsbedingungen verwenden, ohne sich vorher mit dem ROTOFLUX Kundendienst abgesprochen zu haben.

E Rotoflux para maquinas de impresión

Estas juntas están disponibles en dos versiones de sellos mecánicos equilibrados y lapeados :

- Sello N (Sello Estándar) de grafito contra carburo para aplicaciones con agua filtrada.

Se pueden alcanzar presiones superiores a los 8 bar solo con agua fría con una temperatura máxima de 50°C. En el caso de que su aplicación esté al límite de las características técnicas, les rogamos se pongan en contacto con el departamento técnico de ROTOFLUX.

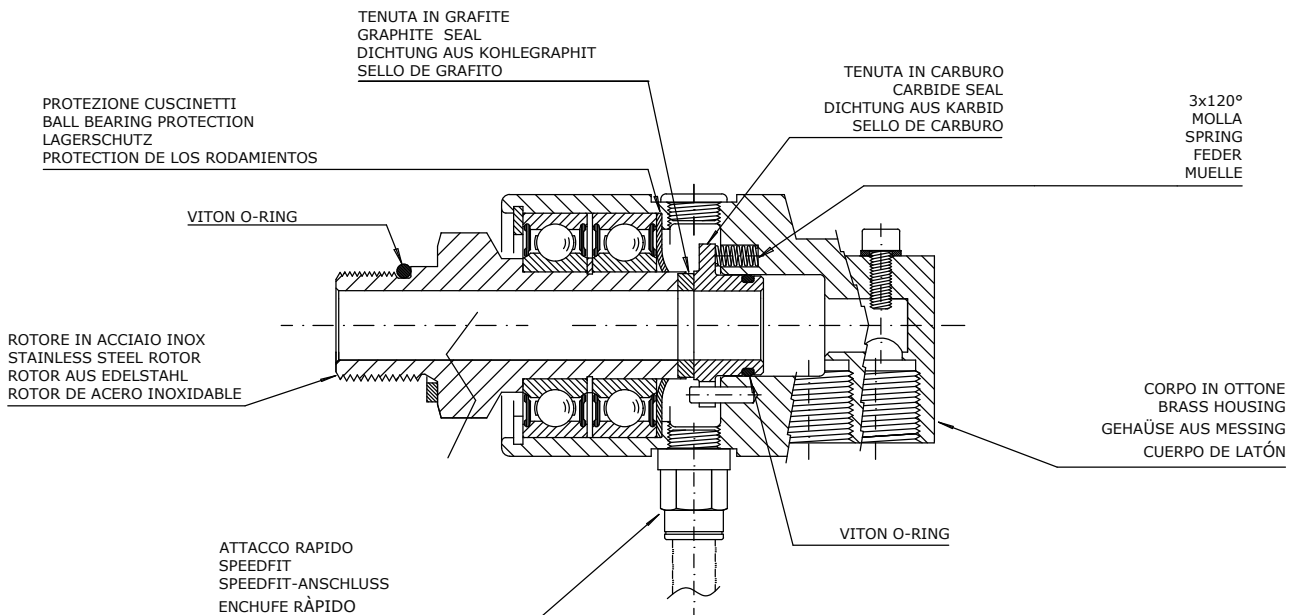

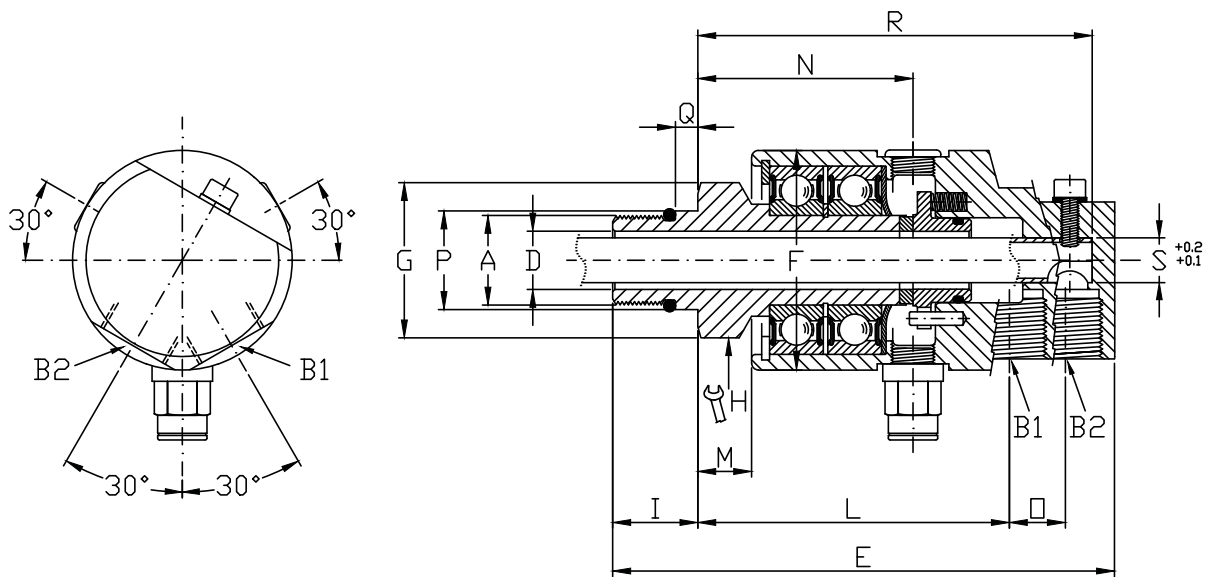

Ordering code	Giunti due passaggi sifone fisso - Double passage stationary siphon unions Zweiwege für stehendes Siphonrohr - Doble vía con sifón fijo																
	Water	A	B1	øD	E	øF	G	H	I	L	M	N	O	øP	Q	R	øS
S10-2382-33R	M16 X 1,5 RH	G 3/8"	10	116	49	24	19	16	76,5	19	55	12,5	18	5	95	8	1
S10-2382-34L	M16 X 1,5 LH																
S15-2382-33R	M20 X 1,5 RH	G 3/8"	13	112	49	-	SW 30	19	69,5	12	48	12,5	21	5	88	8	1
S15-2382-34L	M20 X 1,5 LH																
S15-2386-33R	M20 X 1,5 RH	G 3/8"	13	112	49	-	SW 30	19	69,5	12	48	12,5	21	5	88	10	1
S15-2386-34L	M20 X 1,5 LH																

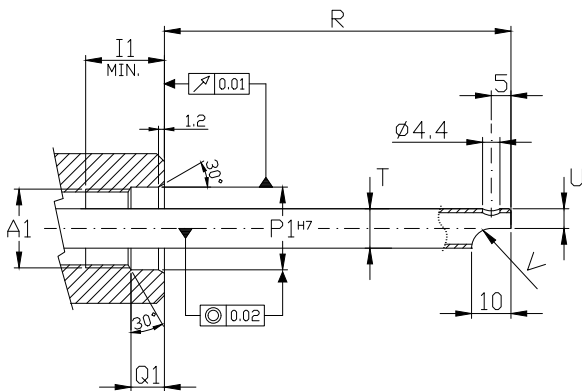

	Interfaccia cliente - Customer interface Montageanweisungen - Montaje de la junta								
	A1	B2	I1	øP1 H7	Q1	R	øT	U	V
S10-2382-33R	M16 X 1,5 RH	G 3/8"	18	18	8.5	95	8 x 1	4	R.4
S10-2382-34L	M16 X 1,5 LH								
S15-2382-33R	M20 X 1,5 RH	G 3/8"	21	21	8.5	88	8 x 1	4	R.5
S15-2382-34L	M20 X 1,5 LH								
S15-2386-33R	M20 X 1,5 RH	G 3/8"	21	21	8.5	88	10 x 1	5	R.5
S15-2386-34R	M20 X 1,5 LH								



Rotoflux per macchine da stampa

Rotoflux for printing machines

Rotoflux für Druckmaschinen

Rotoflux para maquinas de impresión

1/2" ÷ 3/4"



Acqua / Water / Wasser / Agua	50 bar / 725 PSI	95°C / 203°F	3500/5000/7000

I Rotoflux per macchine da stampa

Questi giunti sono disponibili con due tipi di tenute meccaniche bilanciate-microlappate :

- Tenute N (Tenute Normali) in grafite contro carburo per applicazioni con acqua filtrata.

Pressioni sopra 8 bar sono ammesse solo con acqua ad una temperatura max. di 50°C. Non utilizzare i giunti alle massime condizioni di esercizio senza consultare ROTOFLUX.

UK Rotoflux for printing machines

These unions are available with two different balanced and microlapped sealing assemblies :

- N Seal (Standard Sealing) with carbon graphite to carbide seals for application with filtered water.

Fluid pressure over 8 bar is allowed only when the fluid is cool water at max temperature 125°F (50°C). Do not use the unions at max application limits without consulting ROTOFLUX.

DE Rotoflux für Druckmaschinen

Mit zwei unterschiedlichen, feinstgeläpften Dichtungen lieferbar :

- N-Dichtungen (normale Ausführungen) aus Kohlegraphit gegen Karbid, für Anwendungen mit gefiltertem Wasser.

Mediendrucke über 8 bar sind nur für Anwendungen mit kaltem Wasser bis zu Temperatur von 50°C zulässig. Die Drehdurchführungen dürfen nicht unter den maximalen Betriebsbedingungen verwenden, ohne sich vorher mit dem ROTOFLUX Kundendienst abgesprochen zu haben.

E Rotoflux para maquinas de impresión

Estas juntas están disponibles en dos versiones de sellos mecánicos equilibrados y lapeados :

- Sello N (Sello Estándar) de grafito contra carburo para aplicaciones con agua filtrada.

Se pueden alcanzar presiones superiores a los 8 bar solo con agua fría con una temperatura máxima de 50°C. En el caso de que su aplicación esté al límite de las características técnicas, les rogamos se pongan en contacto con el departamento técnico de ROTOFLUX.

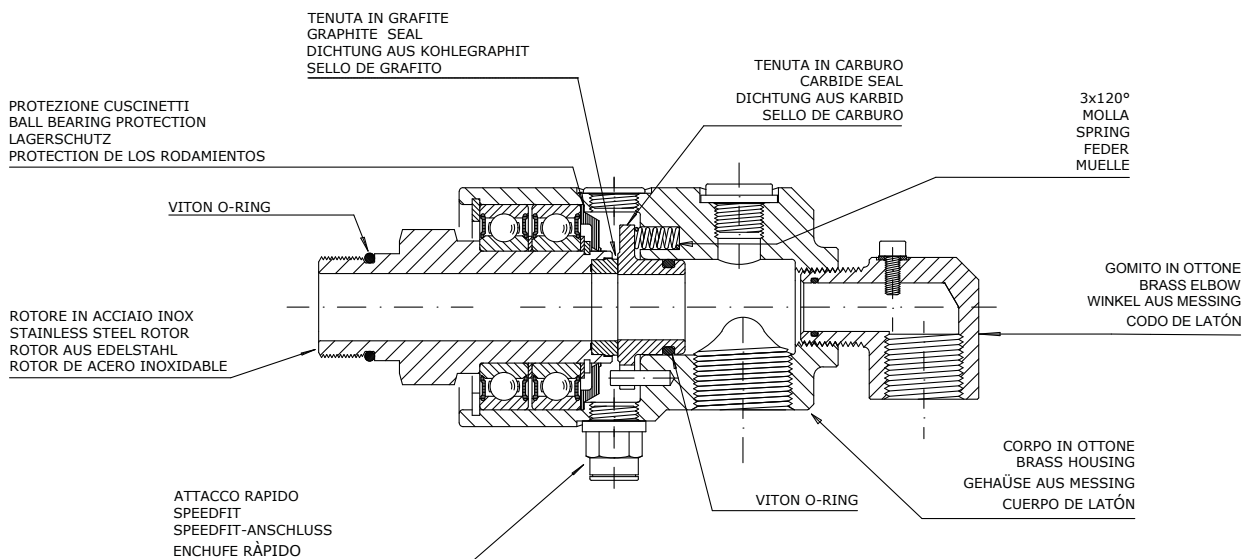

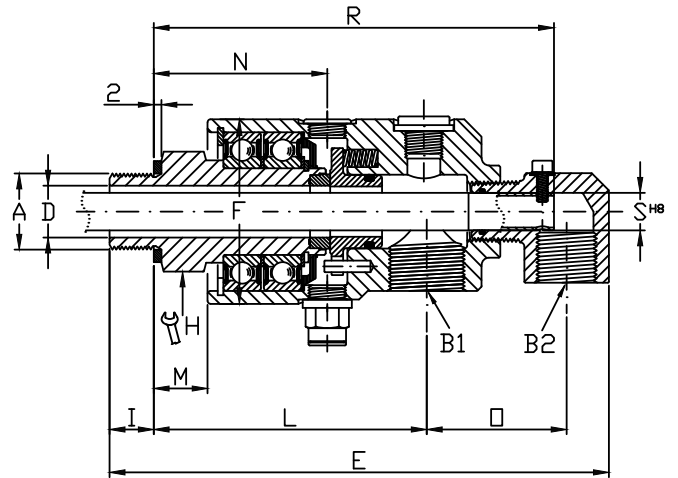
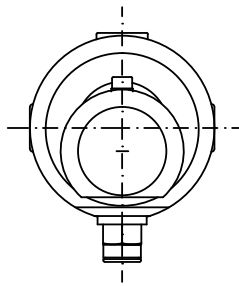

Ordering code	Giunti due passaggi sifone fisso - Double passage stationary siphon unions Zweiwege für stehendes Siphonrohr - Doble vía con sifón fijo														
	Water	A = A1	B1	B2	ø D	E	ø F	H	I	L	M	N	O	R	ø SH8
S15-1292-23R-840	G 1/2" RH	G 1/2"	G 3/8"	13	145	55	SW 30	13	81,5	15	53,5	39,5	118	10	1,5
S15-1292-24L-840	G 1/2" LH														
S20-1292-23R-840	G 3/4" RH	G 3/4"	G 1/2"	18	171	64	SW 36	16	94	18	59,5	46	135	13	2,1
S20-1292-24L-840	G 3/4" LH														

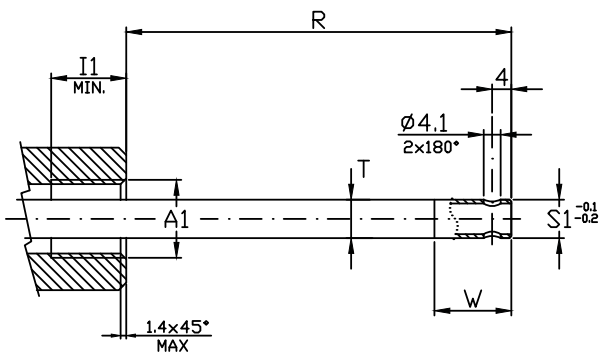

Interfaccia cliente - Customer interface Montageanweisungen - Montaje de la junta						
	A1	I1	R	ø S1	ø T	W
S15-1292-23R-840	G 1/2" RH	20	118	10	10 x 1	26
S15-1292-24L-840	G 1/2" LH					
S20-1292-23R-840	G 3/4" RH	20	135	13	13 x 1	28
S20-1292-24L-840	G 3/4" LH					