



APPLICATIONS

Pumping of liquids in landfill, drainage of liquids from piezometric wells, sampling of fluids in contaminated sites and groundwater.

The ATEX pumps in conformity with 2014/34/EU Directive can be installed in potentially explosive atmospheres according to the marking explained hereafter.

FEATURES

- *Multistage centrifugal electric submersible pumps **for 3" wells.***
- *External pump case, delivery port, suction port, shaft and other components in AISI 316 stainless steel.*
- *Impellers and diffusers in special technopolymer.*
- *Temperature of pumped liquid: max +40 °C.*
- ***Available the version with Maxi-filter 90 or with Slope Riser.***

MOTOR

- *2 poles asynchronous motor, 50 Hz, 2850 rpm.*
- *Class F insulation.*
- *IP68 protection.*
- *Working voltage: single-phase 230 V, three-phase 400 V.*

ACCESSORIES

- *Control panel.*
- *Intrinsically safe module with ATEX supply circuit.*
- *ATEX electronic level transmitter.*
- *TPE-E 4G1,5 composed cable.*

Technical specifications

Pump type	Motor		Cap. µF VL 450	Max current		Outlet Ø	Delivery												
	HP	kW		230 V	400 V		l/min	0	10	15	20	25	30	35	40	45	50	55	
				1~	3~			A	A	m³/h	0	0,6	0,9	1,2	1,5	1,8	2,1	2,4	2,7
316 TREINCH EX 25-20	0,5	0,37	16	3,7	2,3	1"	Manometric head (m)	43	32	24	16	5							
316 TREINCH EX 25-30	0,75	0,55	20	4,5	2,6			63	46	35	22	6							
316 TREINCH EX 40-15	0,5	0,37	16	3,7	2,3			39	36	33	30	26	21	14	5				
316 TREINCH EX 40-22	0,75	0,55	20	4,5	2,6			56	51	45	40	34	28	18	7				
316 TREINCH EX 40-30	1	0,75	25	6	3,2			76	69	62	55	46	38	24	10				
316 TREINCH EX 55-18	0,75	0,55	20	4,5	2,6			46	44	42	39	37	34	30	25	18	10	2	
316 TREINCH EX 55-25	1	0,75	25	6	3,2			62	60	56	54	50	46	40	32	24	12	3	
316 TREINCH EX 55-35	1,5	1,1	—	—	3,5			87	84	79	75	70	65	56	45	33	17	4	

Performance curves

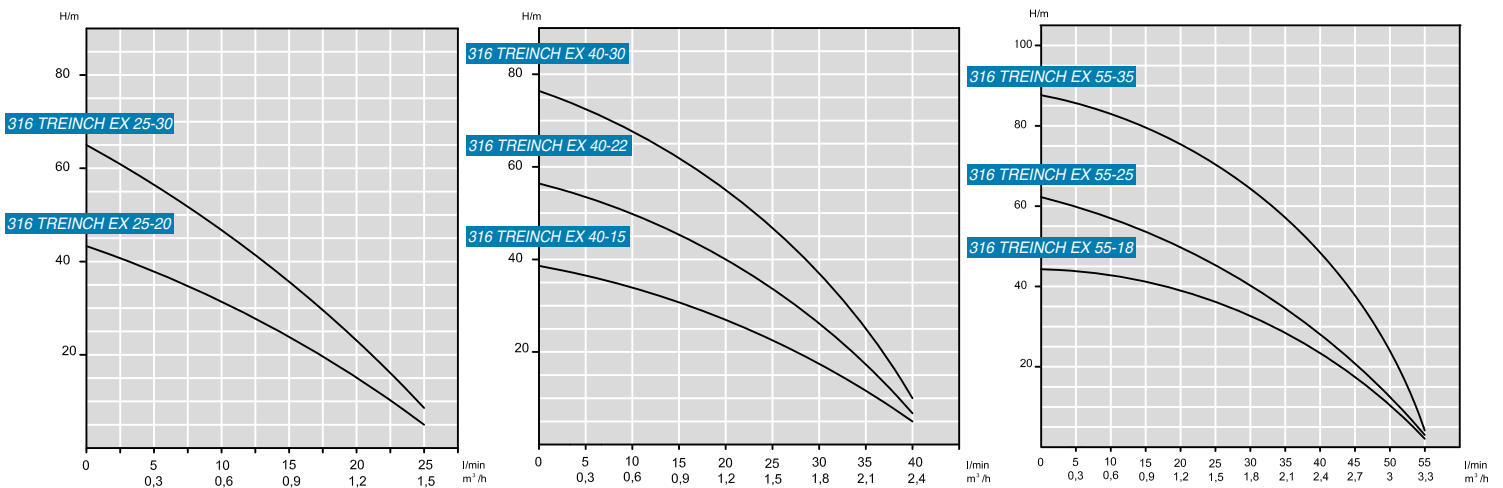

Dimensions and weights

Pump type	Dimensions		Weight					
	mm		kg					
	H		316 TREINCH EX		316 TREINCH EX MAXIFILTER 90		316 TREINCH EX SLOPE RISER	
	230 V 1~	400 V 3~	230 V 1~	400 V 3~	230 V 1~	400 V 3~	230 V 1~	400 V 3~
316 TREINCH EX 25-20	1039	1039	11,6	11,6	14,8	14,8	15,3	15,3
316 TREINCH EX 25-30	1329	1309	13,4	12,9	16,6	16,1	17,1	16,6
316 TREINCH EX 40-15	922	922	10,7	10,7	13,9	13,9	14,4	14,4
316 TREINCH EX 40-22	1106	1086	12,3	11,8	15,5	15	16	15,5
316 TREINCH EX 40-30	1349	1349	13,9	13,4	17,1	16,6	17,6	17,1
316 TREINCH EX 55-18	1059	1039	11,7	11,2	14,9	14,4	15,4	14,9
316 TREINCH EX 55-25	1297	1277	13,5	13	16,7	16,2	17,2	16,7
316 TREINCH EX 55-35	—	1558	—	14,9	—	18,1	—	18,6

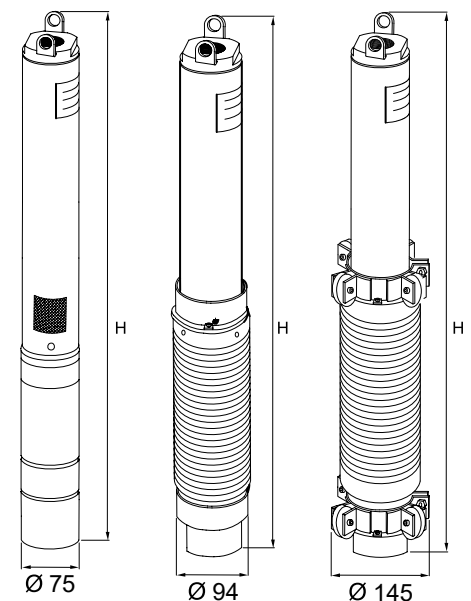

ATEX marking

II Group of apparatus - equipment for surface plants.

2G Category - equipment compatible to be installed in potentially explosive atmospheres with gas, steams and vapors (area 1); this equipment is suitable for area 1 and area 2.

3" ATEX electric pumps and 3" ID ATEX electric pumps protection

Ex Protection against explosions.

eb Type of protection applied to electrical motor – increased safety “e”, level “b” – type of protection applied to electrical apparatus in which additional measures are applied so as to give increased safety against the possibility to excessive temperature and of the occurrence of ark and sparks in normal service or under specified abnormal conditions.

h Type of protection applied to hydraulic part – constructional safety “c” – ignition protection where constructional measures are applied so as to protect against the possibility of ignition from hot surfaces, sparks and adiabatic compression generated by moving parts

mb Type of protection applied to connection facility to external circuits – encapsulation “m”, level “b” – type of protection whereby parts that are capable of igniting an explosive atmosphere by either sparking or heating are fully enclosed in a compound or other non-metallic enclosure with adhesion in such a way as to avoid ignition of a dust layer or explosive atmosphere under operating or installation conditions.

ob Type of protection applied to electrical motor – liquid immersion “o”, level “b” – type of protection in which the electrical equipment or parts of the electrical equipment are immersed in a protective liquid in such a way that an explosive gas atmosphere which may be above the liquid or outside the enclosure cannot be ignited.

IIC Subgroup of gas: equipment compatible to be installed with all combustible gas.

T4 Class temperature – maximum temperature of the equipment 135 °C.

Gb Protection level of equipment compatible to be installed in potentially explosive atmospheres with combustible gas - level b.