

Gemux



Type: FPM/PP
SN: 30E03069E
Date: 25/11/2024
Maximum Temperature: 40°C
Mass: 1.7kg
CE UK CB

KemFlow

Water-driven
dosing pumps

Industry Applications



Water Treatment

For every chemical dosing requirement in water-treatment applications – from legionella control to maintaining hot and cold-water networks – our superior KemFlow water-driven pumps deliver efficiency, longevity and sustainability in equal measure. Whether treating drinking water, process water or wastewater, these cutting-edge systems help operators achieve optimal system performance and chemical consumption while meeting ever-changing environmental legislation.



Agriculture

Farmers around the world benefit from the precision and consistency of KemFlow water-driven dosing pumps, which are used to inject fertiliser, pesticides and other additives into irrigation water. This means growers can rely on their equipment to help achieve healthy crops and enjoy improved yields for increased profitability while these systems' superior dosing accuracy means chemical and water waste is minimised.



Livestock

In livestock applications as varied as poultry farming, pig rearing and rabbit breeding, KemFlow water-driven pumps are the go-to solution for protecting animal health in order to prevent the spread of disease. From the injection of vaccines and medicine into livestock drinking water to the sanitisation of pipelines, these versatile systems give breeders peace of mind at all times.



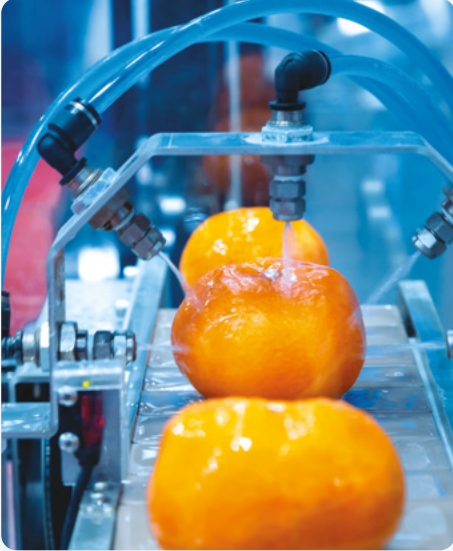

Food & Hygiene

Wherever there is a need for exceptional hygiene in the production, preparation and service of food and beverage products, KemFlow water-driven dosing pumps are present, helping operators to cover a multitude of disinfection requirements.

These dedicated systems ensure managers can maintain the highest standards of hygiene across sites such as restaurants and hospitals where public health protection is paramount.



Industry

Industrial processes require solutions that are robust and durable without compromising on performance, which is why our KemFlow water-driven pumps are the dosing solution of choice for operators of demanding applications within the graphic and metalworking industries to name just two. From vibro-abrasion, degreasing and legionella control to mineral dosing and wetting agent injection, these versatile systems cover myriad processes.



Car Wash

In the ever-demanding automotive care sector where exceptional results must be achieved as standard, KemFlow water-driven dosing pumps offer high-precision chemical injection solutions for tunnel wash, self-serve and gantry wash systems and many other commercial car wash applications. These systems help managers minimise chemical, water and energy consumption while maintaining consistent results as part of a sustainable, profitable operation.

KemFlow

Automatic chemical dosing systems

SEKO's KemFlow water-driven pumps are the latest addition to our world-leading range of chemical dosing systems, offering an alternative to automatic solenoid, peristaltic and motor-driven metering to serve a vast range of applications.

Installed directly in the water supply line, KemFlow uses water pressure as its power source and automatically mixes concentrated chemical proportional to water volume regardless of variations in flow or pressure which may occur in the main line.

This ultra-reliable dosing method means operators can depend upon consistent performance in applications as varied as water treatment, automotive care and industrial processes.

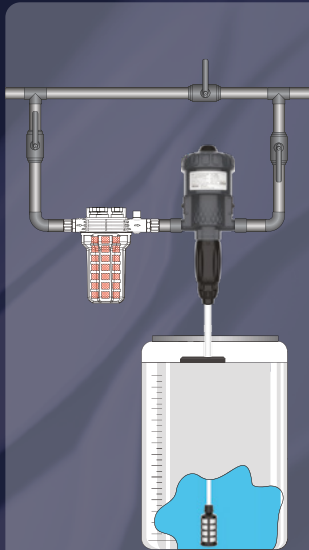
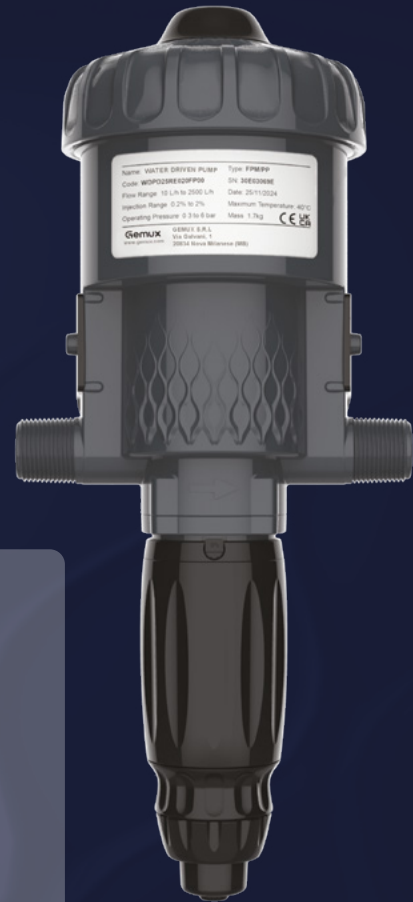

Pump installation

In order to optimise your installation and get the most out of your water-driven pump, we recommend the following guidelines are met:

- Refer to local water regulations
- Install a filter upstream depending on water quality
- Change dosing seals at least once a year
- Rinse as often as possible with clean water
- Turn off water supply and allow pressure to drop to zero before adjusting injection rate
- Install necessary protections for excess flow, excess pressure and water hammer

Features

- Easily regulated injection rate
- Portability (emergency skids)
- Low operating and maintenance costs
- Dose any liquid or water-soluble product
- Precise, repeatable dosing
- Non-electric (energy saving)
- Simple dosage adjustment (in % increments)
- Self-priming and efficient mixing
- Optimal water and polymer consumption
- Reduced cleaning and maintenance time
- Automatic dosing stops in event of water flow ceasing

Specification

Model	D25RE020	D25RE050	D25RE100
Injection Dosage	0.2 – 2%	1 – 5%	3 – 10%
Water Flow Rate*	10 - 2,500 l/h	10 – 2,500 l/h	10 – 2,000 l/h
Pressure	0.3 – 6 bar	0.3 – 6 bar	0.3 – 4 bar
Concentrated Additive Injection Rate	0.02 – 50 l/h	0.1 – 125 l/h	0.3 – 200 l/h

*For others fluids than water, please contact us

 **Features & benefits**

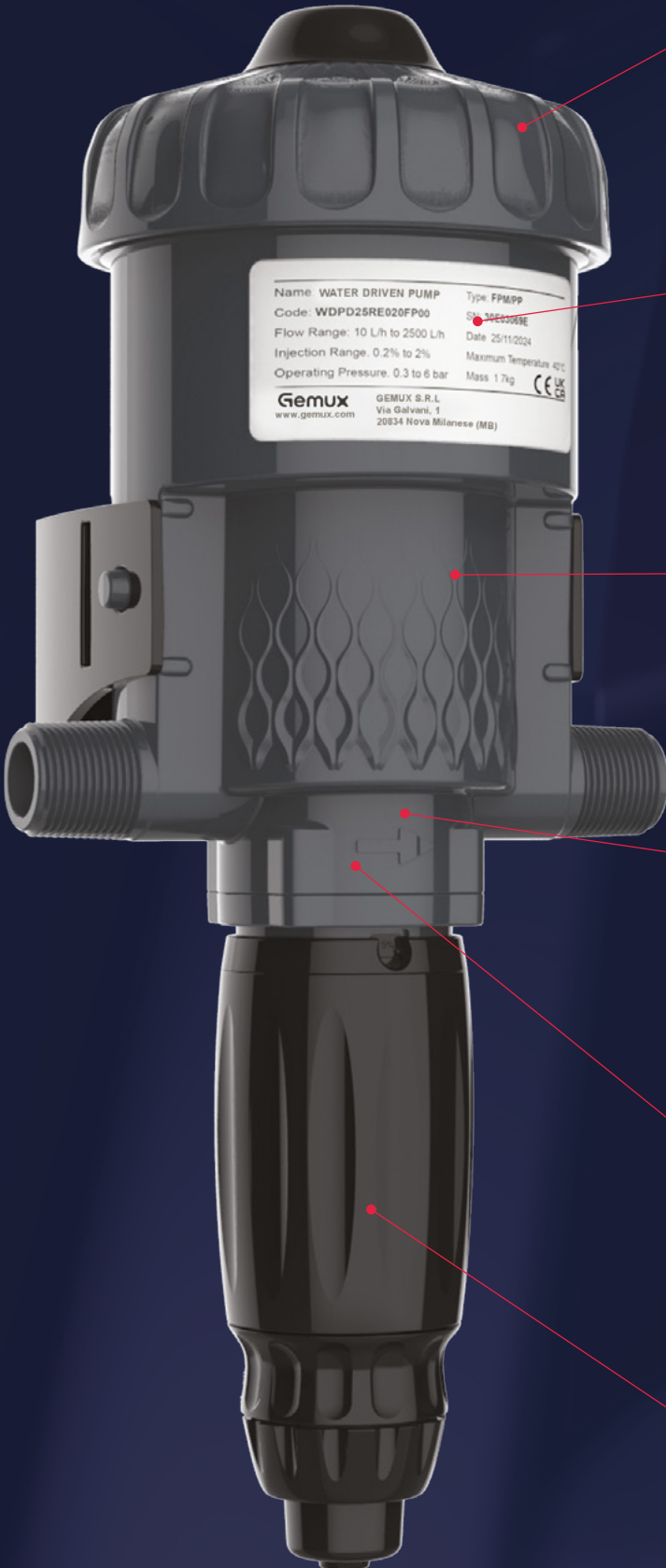

Name: WATER DRIVEN PUMP Type: FPMPP
 Code: WDPD25RE020FP00 Sp: 30E0339E
 Flow Range: 10 L/h to 2500 L/h Date: 25/11/2024
 Injection Range: 0.2% to 2% Maximum Temperature: 45°C
 Operating Pressure: 0.3 to 6 bar Mass: 1.7kg CE 25

Gemux S.R.L.
 Via Galvani, 1
 20834 Nova Milanese (MB)



Low operating & maintenance costs

KemFlow's robust components and intelligent design make the system inexpensive to both run and maintain



High-precision, repeatable dosing

Operators can depend upon KemFlow to dose a range of chemicals with superior accuracy every time



Non-electric

The pump's absence of electrical connection makes it the perfect solution for operators seeking to achieve precise dosing even in remote locations



Reduced cleaning & servicing time

The exceptional build quality of KemFlow allows operators to spend minimal time servicing the system



Self-priming & efficient mixing

Removing the need for manual priming, KemFlow brings speed and efficiency to every dosing application



Easily regulated injection rate

With an adjustable dosing percentage depending on the selected model, users enjoy ultra-tight control to prevent chemical wastage and associated costs

KemFlow water-driven pump technology

Water-driven pump technology is based on a hydraulic motor pump activated only by pressure and water flow. Installed directly on the water supply line, the pump operates by using the water flow rate as a source of energy.

The pressure and flow rate of the water actuate the motor piston which drives a second, product-dosing piston. The product is injected and mixed continuously with the water from the mains supply at the selected dosing rate percentage (rate of product/water incorporation). The dose of concentrated product is directly proportional to the volume of water passing through the pump, independent of variations in the flow rate and pressure of the mains water supply.

Hydraulic motor

The motor piston moves under water pressure, with a system of valves allowing the movement to be reversed.

Each piston cycle corresponds to a predetermined volume of water which passes through the pump (motor volume). The speed of the motor varies proportionally with water flow.

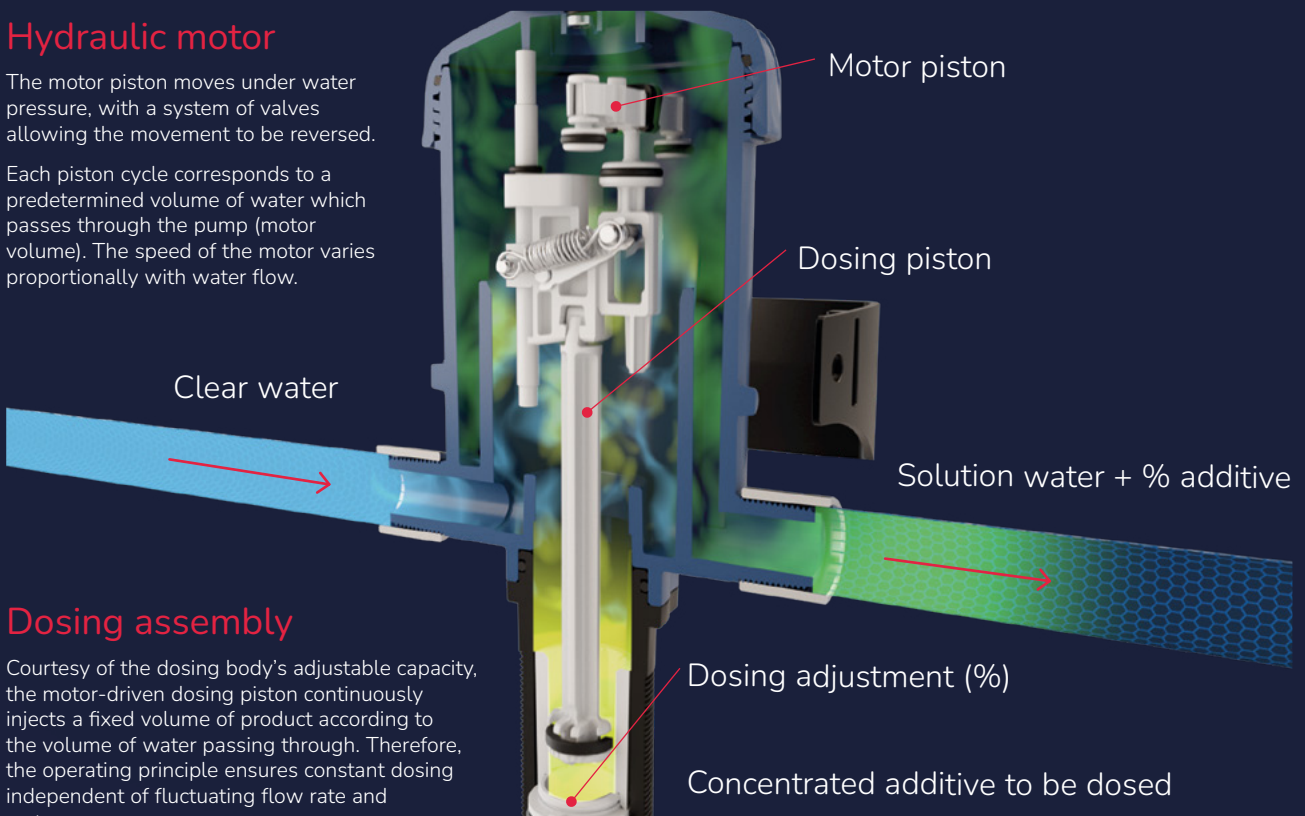

Dosing assembly

Courtesy of the dosing body's adjustable capacity, the motor-driven dosing piston continuously injects a fixed volume of product according to the volume of water passing through. Therefore, the operating principle ensures constant dosing independent of fluctuating flow rate and water pressure.

**Choose the power
of hydraulic dosing**

KemFlow key code

Model							
WDP	Water driven pump.						
Type	Pressure [bar]	Flow rate [L/h]	Ø Hydr Connections IN / EXT. [mm]	Concentrated product injection rate [L/h]		Adjustable dosage [%] [L]	
D25	0.3 - 6	10 - 2,500	¾" M BSP-NPT Ø 20 x 27mm	0.02 - 50		0.2 - 2	500 - 50
	0.3 - 4	10 - 2,000		0.1 - 125		1 - 5	100 - 20
				0.3 - 200		3 - 10	33 - 10
Injection dosage							
RE	Adjustable						
	Dosage range	%	1:				
	020	2	50				
	050	5	20				
	100	10	10				
Seals							
	F	FPM					
	E	EPDM					
	A	AFLAS					
Body material							
	P	PP					
	V	PVDF					
Mixing device							
	0	Internal					
Market							
	0	Western					
WDP	D25	RE	020	F	V	0	0



KemFlow with PP body

- The ideal general-purpose pump
- Broad chemical compatibility
- Suitable for fresh, salt and deionised water
- Commonly used for chemicals as varied as formaldehyde, potassium and sulfuric acid



KemFlow with PVDF body

- Exceptional chemical compatibility
- Superior thermal stability and resistance to stress cracks
- High corrosion resistance

A passion for industrial solutions

Since 1997, Gemux has been the partner of choice for discerning operators seeking design, construction and maintenance of industrial plants, skids and machines.

With a wide range of expertise across restoration, overhauls and new installations, we create tailor-made solutions to improve process efficiency and sustainability.

Gemux is a byword for reliability – a name you can always trust to deliver on time and to your precise specification.

Whether it's rapid response, excellent communication, superior knowledge of industrial applications or a broad portfolio of solutions, choose Gemux for a service you can depend upon.

Gemux

T +39 0362 1701279

E info@gemux.com

W gemux.com

Via Galvani, 1

20834 Nova Milanese (MB)

Gemux products are intended for professional use in industrial applications only and are not available for domestic or retail sale. Gemux reserves the right to amend and change specifications without prior notice. All pictures shown are for illustration purpose only. Actual product may vary due to product enhancement. Published data may be subject to change.

© 2025 GEMUX, Layout and origin: Eventus Labs, UK, 850003 WTCATA-DUO EN V01

Gemux.com