



TECHNICAL DATA

- Connections:
 - Fluid 2" - DN50
 - Air 3/4"
- Max flow rates: 650 l/min
- Max air pressure: 8 Bar
- Max delivery head: 80 m
- Max suction head:
 - Dry 4.5 m
 - Wet 9.8 m
- Max d. passing solids: 8.5 mm
- Noise level: 95 dB
- Displacement for cycle: 3.000 cc
- Pump casing materials:
 - PP
 - PVDF+CF
 - ALUMINIUM
 - SS 316
- Max viscosity: 50.000 cPs

Pneumatic Diaphragm Pumps are characterized by exceptional performance, power and strength, making them ideal for pumping liquids with very high apparent viscosity up to 55.000 cPs (at 20°C), even if they contain suspended solids.

The stall-prevention pneumatic system assures a safe pump running and it does not need lubricated air. Self-priming dry capacity even with considerable suction head, fine tuning of speed without pressure loss and the possibility of dry operation without suffering damage mean that these pumps offer unrivalled versatility. In addition, the huge choice of construction materials allows selection of optimum chemical compatibility with the fluid and/or environment without neglecting the temperature range.

DIMENSIONS (all materials)

| | A | B | C | Weight | Temperature |
|-------------|--------|--------|--------|---------|---------------|
| PP | 571 mm | 395 mm | 620 mm | 37.5 kg | - 4°C + 65°C |
| PVDF | 571 mm | 395 mm | 620 mm | 47.5 kg | - 20°C + 95°C |
| ALU | 511 mm | 395 mm | 662 mm | 45 kg | - 20°C + 95°C |
| SS | 495 mm | 395 mm | 635 mm | 85 kg | - 20°C + 95°C |

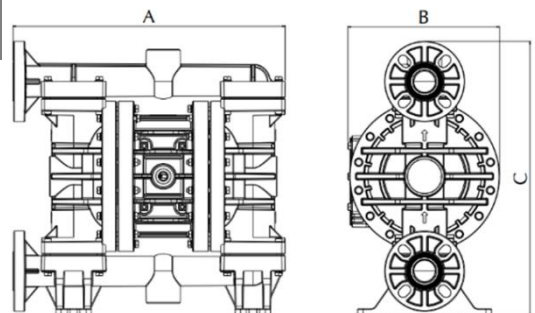

CODE KEY

| model | | | | | | | | | | | | |
|--------------------|-----------------|---|-----------------|--------------|-------------------|------------------|------|----------------|---------------------|----------------|---------------------------------------|---|
| GX | | | | | | | | | | | | |
| type | | | | | | | | | | | | |
| 0 | | Standard pump | | | | | | | | | | |
| N | | External pump control WITHOUT solenoid | | | | | | | | | | |
| Y | | External pump control WITH solenoid | | | | | | | | | | |
| series | flow rate [l/1] | connections fluid | connections air | max head [m] | max pressur [bar] | self priming [m] | | passing [Ø mm] | max viscosity [Cps] | displac./ [cc] | max frequency [cycle/1] - [2x Str./1] | |
| 700 | 650 | DN50 - 2" | 3/4" | 80 | 8 | 4.5 | - 10 | 8.5 | 50000 | 3000 | 220 | |
| connections | | | | | | | | | | | | |
| 2 | | Flanged (or BSP Threaded + kit Flanged) | | | | | | | | | | |
| pump head material | | | | | | | | | | | | |
| P | | Polypropylene + Glass Fiber | | | | | | | | | | |
| K | | PVDF + Carbon Fiber | | | | | | | | | | |
| S | | SS316 | | | | | | | | | | |
| A | | Aluminium | | | | | | | | | | |
| air diaphragm | | | | | | | | | | | | |
| H | | Hytel | | | | | | | | | | |
| M | | Santoprene | | | | | | | | | | |
| D | | EPDM | | | | | | | | | | |
| N | | NBR | | | | | | | | | | |
| fluid diaphragm | | | | | | | | | | | | |
| X | | without "T" diaphragm | | | | | | | | | | |
| T | | PTFE | | | | | | | | | | |
| balls | | | | | | | | | | | | |
| T | | PTFE | | | | | | | | | | |
| S | | AISI 316 | | | | | | | | | | |
| D | | EPDM | | | | | | | | | | |
| N | | NBR | | | | | | | | | | |
| ball SEATS | | | | | | | | | | | | |
| P | | Polypropylene | | | | | | | | | | |
| K | | PVDF | | | | | | | | | | |
| S | | SS316 | | | | | | | | | | |
| A | | Aluminium | | | | | | | | | | |
| Z | | PE-UHMW | | | | | | | | | | |
| O-rings | | | | | | | | | | | | |
| V | | FPM | | | | | | | | | | |
| D | | EPDM | | | | | | | | | | |
| N | | NBR | | | | | | | | | | |
| T | | PTFE | | | | | | | | | | |
| opening | | | | | | | | | | | | |
| AB | | standard [A - suction / B - delivery] | | | | | | | | | | |
| market | | | | | | | | | | | | |
| 0 | | western | | | | | | | | | | |
| 8 | | Chinese | | | | | | | | | | |
| customizations | | | | | | | | | | | | |
| 0 | | standard | | | | | | | | | | |
| GX | 0 | 700 | 2 | P | H | T | T | P | T | AB | 0 | 0 |

HYDRAULIC CHARACTERISTICS

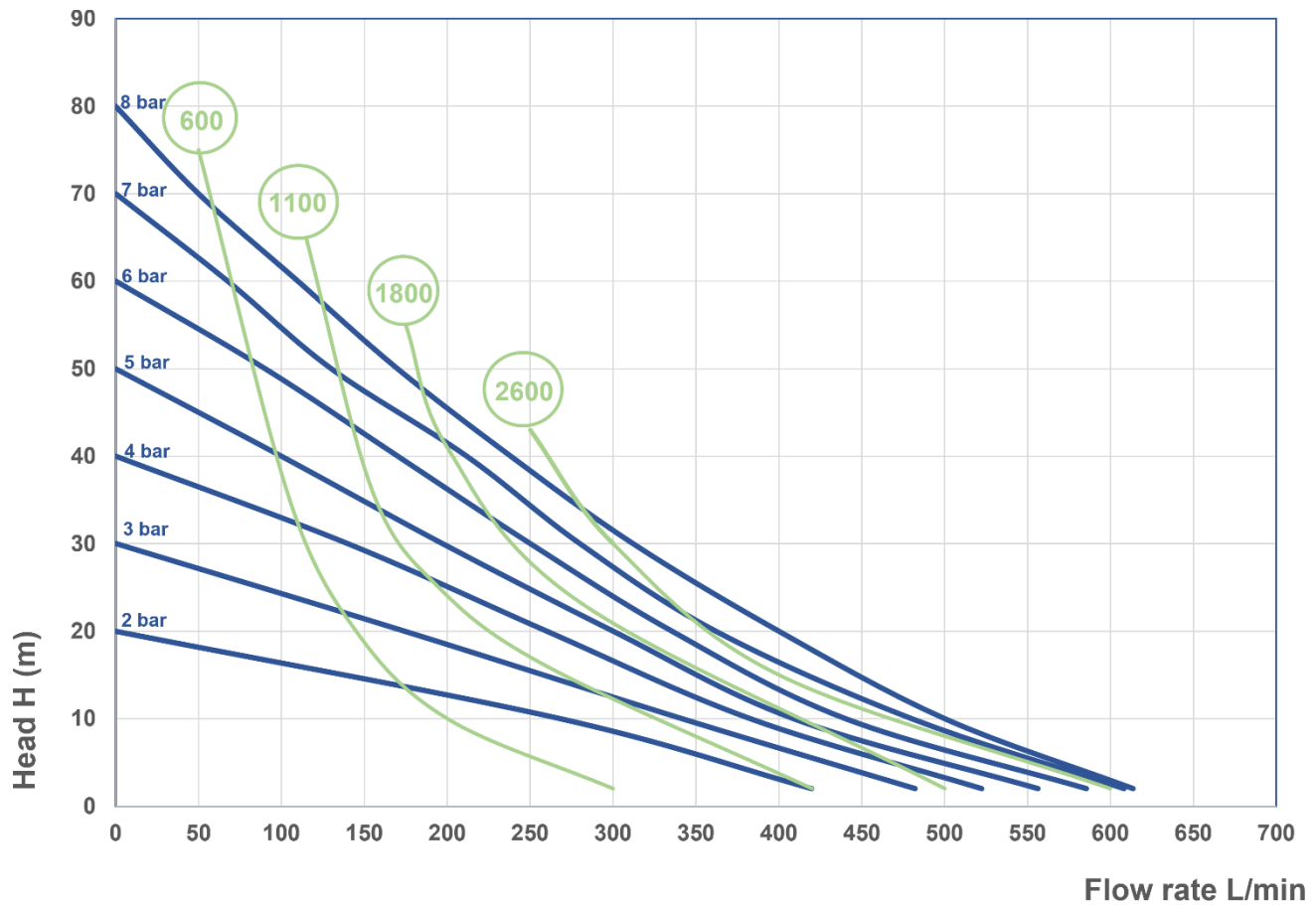

* The curves and performance values refer to pumps with submerged suction and a free delivery outlet with water at 20°C and vary according to the construction material.

AVAILABLE CONNECTIONS (indicative image - follow the diagram)

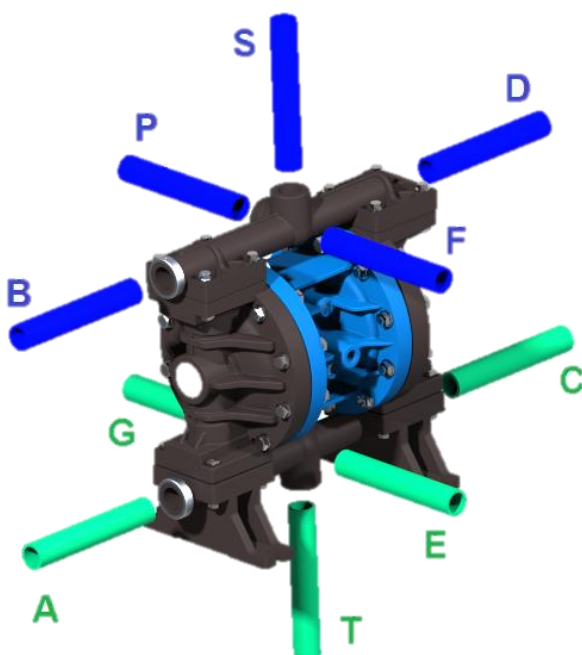

(AL & AISI)

Standard = E F

IN = E-T-G

OUT = F-S-P

(PP & PVDF)

Standard = A-B

IN = A-E-T-C-G

OUT = B-S-D-F-P

OPERATING PRINCIPLE

The air valve directs pressurized air to the back side of diaphragm A. The compressed air is applied directly to the liquid column separated by elastomeric diaphragms. The diaphragm acts as a separation membrane between the compressed air and liquid, balancing the load and removing mechanical stress from the diaphragm. The compressed air moves the diaphragm away from the center block of the pump. The opposite diaphragm is pulled in by the shaft connected to the pressurized diaphragm. Diaphragm B is on its suction stroke; air behind the diaphragm has been forced out to the atmosphere through the exhaust port of the pump. The movement of diaphragm B toward the center block of the pump creates a vacuum within chamber B. Atmospheric pressure forces fluid into the inlet manifold forcing the inlet valve ball off its seat. Liquid is free to move past the inlet valve ball and fill the liquid chamber (see shaded area).

When the pressurized diaphragm, diaphragm A, reaches the limit of its discharge stroke, the air valve redirects pressurized air to the back side of diaphragm B. The pressurized air forces diaphragm B away from the center block while pulling diaphragm A to the center block. Diaphragm B is now on its discharge stroke. Diaphragm B forces the inlet valve ball onto its seat due to the hydraulic forces developed in the liquid chamber and manifold of the pump. These same hydraulic forces lift the discharge valve ball off its seat, while the opposite discharge valve ball is forced onto its seat, forcing fluid to flow through the pump discharge. The movement of diaphragm A toward the center block of the pump creates a vacuum within liquid chamber A. Atmospheric pressure forces fluid into the inlet manifold of the pump. The inlet valve ball is forced off its seat allowing the fluid to be pumped to fill the liquid chamber.

At completion of the stroke, the air valve again redirects air to the back side of diaphragm A, which starts diaphragm B on its exhaust stroke. As the pump reaches its original starting point, each diaphragm has gone through one exhaust and one discharge stroke. This constitutes one complete pumping cycle. The pump may take several cycles to completely prime depending on the conditions of the application.

