

NM, NMS

Close Coupled Centrifugal Pumps with flanged connections



Construction

Close-coupled centrifugal pumps; electric motor with extended shaft directly connected to the pump up to 22 kW, new bracket construction for standard motors (stub-shaft construction) from 30 to 75 kW with integrated thrust bearing.

Pump casing with axial suction and radial delivery on top, main dimensions and performance according to EN 733.

NM(S): version with pump casing and lantern bracket in cast iron.

B-NM(S): version with pump casing and lantern bracket/casing cover in bronze. (the pumps are supplied fully painted).

Connections: Flanges according to PN 10, EN 1092-2.

Counter-flanges (on request)

Sizes	Flanges
from NM 32/.. to NM 50/...	Screwed flanges EN 1092-1, PN 16
from NM 65/.. to NMS 100/...	Flanges for welding EN 1092-1, PN 10

Version with frequency converter (on request)

Applications

For clean liquids without abrasives, which are non-aggressive for the pump materials (solids content up to 0,2%). For water supply.

For heating, air conditioning, cooling and circulation plants.

For civil and industrial applications.

For fire fighting applications. For irrigation.

Operating conditions

Liquid temperature from -10 °C to +90 °C.

Ambient temperature up to 40° C.

Total suction lift up to 7 m.

Maximum permissible working pressure up to 10 bar (16 bar for NM 40/16,20; NM 50/12,16; NM 65/12,16,20,25; NM 80/16).

Continuous duty.

Motor

2-pole induction motor, 50 Hz (n ≈ 2900 rpm).

NM, NMS: three-phase 230/400 V ± 10% up to 3 kW; 400/690 V ± 10% from 4 to 75 kW.

Insulation class F. Protection IP 54 (IP 55 for NMS).

Motor suitable for operation with frequency converter from 1,1 kW.

Classification scheme IE3 for three-phase motors from 0,75 kW.

Constructed in accordance with: EN 60034-1; EN 60034-30-1.

Special features on request

- Other voltages.
- Frequency 60 Hz (as per 60 Hz data sheet).
- Protection IP 55.- Special mechanical seal.
- Packed gland (only for NM standard construction).
- Single-phase motor (NMM) up to 1,5 kW.
- Higher or lower liquid or ambient temperatures.
- Motor suitable for operation with frequency converter up to 0,75 kW.

The electropumps NM, B-NM, NMS, B-NMS series comply with the European Regulation no. 547/2012.

Materials

Components	NM, NMS	B-NM, B-NMS
Pump casing	Cast iron	Bronze
Lantern bracket NM	GJL 200 EN 1561	G-Cu Sn 10 EN 1982
Casing cover for NMS		
Lantern bracket NMS	Cast iron GJL 200 EN 1561	
Impeller	Cast iron GJL 200 EN 1561	Bronze G-Cu Sn 10 EN 1982
	Brass P- Cu Zn 40 Pb 2 UNI 5705 for NM 32/12-16-20, NM 40/20, B-NM 32/125-160-200, B-NM 40/200	
Shaft	AISI 303 up to 2.2 kW AISI 430 from 3 kW to 75 kW	Cr Ni Mo steel AISI 316
Mechanical seal	Carbon - Ceramic - NBR	
Counter-flanges	Steel Fe 430B UNI 7070	

Coverage chart n ≈ 2900 rpm

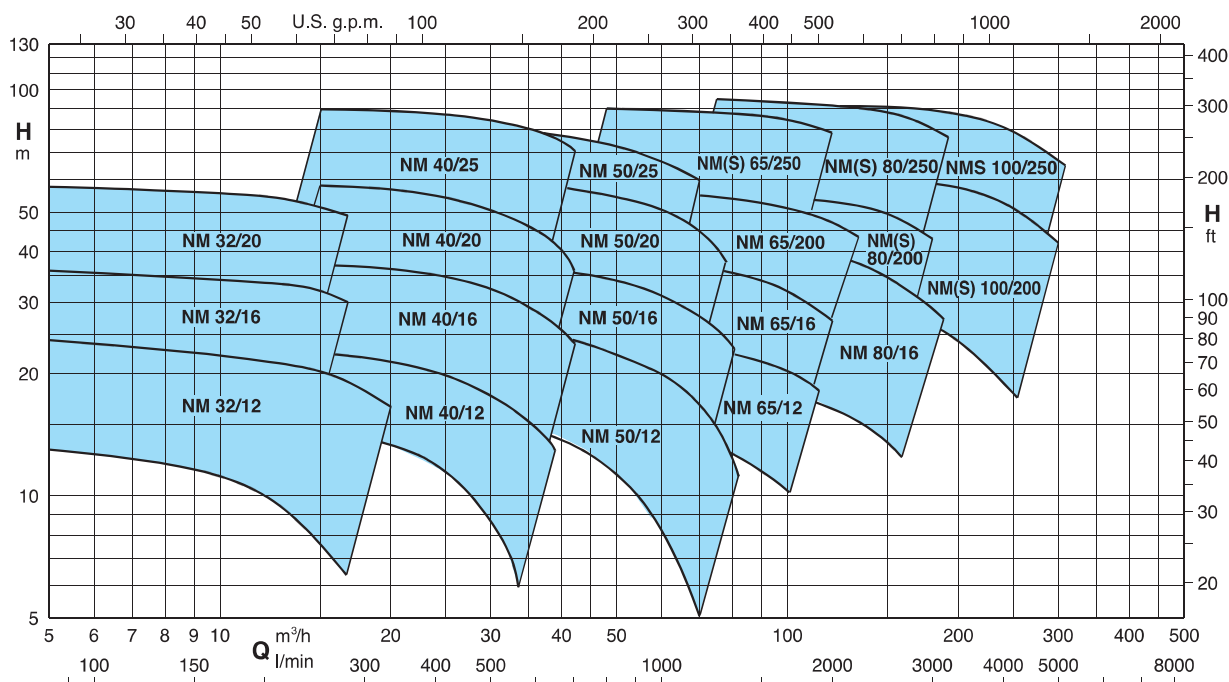

Pumps with frequency converter

The **NM EI** pumps are available with power from 0,55 kW up to 22 kW, the pumps are equipped with **I-MAT** installed on board which allows to realize a variable-speed system extremely compact and efficient, ideal in applications of water supply and in the distribution of hot and cold water.

The pump is equipped with transducers suitable for operation and is already programmed at the factory.

Advantages

- Energy saving
- Compact design
- Easy to use
- Programmable to suit the system requirements
- Reliability

Costruction

The system comprises of:

- Pump
- Induction motor
- I-MAT Frequency converter
- Motor adapter for the motor mounting of the frequency converter
- Connection cable between frequency converter and induction motor
- Transducers

Main features

- Rated motor power output from 0,55 kW to 22 kW
- Control range from 1750 to 2900 rpm (2-pole)
- Protection against dry running
- Protection against operations with closed valve ports
- Protection against system leakages
- Protection against overcurrent in the motor
- Protection against overvoltage and undervoltage of the power supply
- Protection against current unbalances between phases



Operating modes



Constant pressure mode with pressure transducer

In this mode, the system maintains the preset pressure when the flow required by the installation changes.

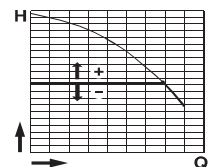

Proportional pressure mode with pressure transducer

In this mode the system changes the working pressure according to the required flow rate.

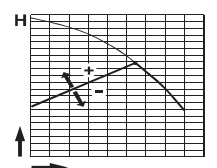

Constant flow mode with flow meter

In this mode the system maintains a constant flow rate value in a point of the installation according to the required pressure.

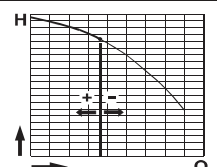

Fixed speed mode with setting of the speed preferential rotation.

In this mode, by changing the working frequency, you may choose any operational curve included within the working range.

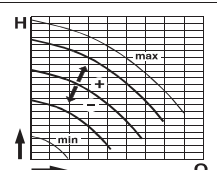

Constant temperature mode with temperature transducer

In this mode the system keeps the temperature constant inside a system by changing the speed of the pump.

Performance n ≈ 2900 rpm

B-NM	NM	P ₂		Q m³/h	6,6	7,5	8,4	9,6	10,8	12	13,2	15	16,8	18,9	21	24	27	30
		kW	HP		l/min	110	125	140	160	180	200	220	250	280	315	350	400	450
B-NM 32/12F	NM 32/12FE	0,55	0,75	H m	12,5	12,5	12	11,5	11	10	9	7,5						
B-NM 32/12D	NM 32/12DE	0,75	1		18	18	17,5	17	16,5	16	15,5	14						
B-NM 32/12A/A	NM 32/12A/A	1,1	1,5		23	23	22,5	22	21,5	21	20,5	19						
B-NM 32/12S/A	NM 32/12S/A	1,5	2		23,5	23,5	23	22,5	22	21,5	21	20,5	19	18,5	16,5	13		
B-NM 32/16B/A	NM 32/16B/A	1,5	2		29,5	29,5	29	28,5	27,5	27	26	25*	22,5*					
B-NM 32/16A/B	NM 32/16A/B	2,2	3		35,5	35,5	35	34,5	34	33,5	33	32*	30*					
B-NM 32/20D/B	NM 32/20D/B	2,2	3		38	37,5	37	36	35	33,5	32							
B-NM 32/20C/A	NM 32/20C/A	3	4		45	44,5	44	43,5	42,5	41	40	38	36					
B-NM 32/20A/B	NM 32/20A/B	4	5,5		57,5	57	56	55,5	55	54,5	53,5	51,5	49					

B-NM	NM	P ₂		Q m³/h	15	16,8	18,9	21	24	27	30	33	37,8	39	42	45	48	54
		kW	HP		l/min	250	280	315	350	400	450	500	550	630	650	700	750	800
B-NM 40/12F/A	NM 40/12F/B	1,1	1,5	H m	14	13,5	13	12	11	9,5	8	6						
B-NM 40/12C/A	NM 40/12C/B	1,5	2		17,5	17	16,5	16	15	13,5	12	10,5	7,5	6,5				
B-NM 40/12A/B	NM 40/12A/C	2,2	3		22	22	21,5	21	20	19	18	16,5	14	13	11,5			
B-NM 40/16C/B	NM 40/16C/C	2,2	3		23	22,5	22	21,5	20	18,5	16,5	14,5	11	10				
B-NM 40/16B/A	NM 40/16B/B	3	4		29	28,8	28	27,5	26,5	25	23,5	21,5	18	17	14			
B-NM 40/16A/B	NM 40/16A/C	4	5,5		37	36,5	36,5	36	35	33,5	32	30,5	27	26	23,5	20	17	
B-NM 40/20D/B	NM 40/20D/C	4	5,5		39	38	37	35,5	33,5	30,5	27	22,5	14					
B-NM 40/20C/B	NM 40/20C/C	4	5,5		41,5	40,5	39,5	38	36	33,5								
B-NM 40/200B/A	NM 40/20B/A	5,5	7,5		50	49,5	48,5	47,5	45,5	43,5	41,5	37,5	30,5					
B-NM 40/200AR/A	NM 40/20AR/A	5,5	7,5		55	54,5	54	53	51	49								
B-NM 40/200A/A	NM 40/20A/A	7,5	10		57,5	57	56,5	55,5	54,5	52,5	50,5	48	42,5	40,5	35			
B-NM 4025/C/C	NM 40/25C/C	9,2	12,5		61	61	60,5	59,5	58,5	56,5	53,5	49,5	41,5	40	33,5			
B-NM 4025/B/C	NM 40/25B/C	11	15		69,5	69,5	69	68,5	67	65,5	63,5	60,5	53,5	51	45			
B-NM 4025/A/C	NM 40/25A/C	15	20		90	90	89,5	89	88,5	87	85	83	77,5	76	70,5			

B-NM	NM	P ₂		Q m³/h	24	27	30	33	37,8	42	48	54	60	66	69	72	75	78	81	84	
		kW	HP		l/min	400	450	500	550	630	700	800	900	1000	1100	1150	1200	1250	1300	1350	1400
B-NM 50/12F/B	NM 50/12F/C	2,2	3	H m			15,5	15	14	13,5	12	10	8	6							
B-NM 50/12D/A	NM 50/12D/B	3	4				20	19,5	18,5	18	16,5	14,5	13	10,5	9	8					
B-NM 50/12A/B	NM 50/12A/C	4	5,5				24	24	23	22,5	21	19,5	17,5	15	14	12,5	11,5	10			
B-NM 50/12S/B	NM 50/12S/C	4	5,5				26,5	26	25,5	24,5	23,5	22	20	18	16,5	15,5	14	13	11		
B-NM 50/160B/B	NM 50/16B/B	5,5	7,5				31	30,5	29,5	28	26	24	21,5	19	17,5	15,5	13,5	11,5	9,5		
B-NM 50/160A/B	NM 50/16A/B	7,5	10				38,5	38	37,5	36,5	34,5	32,5	30	27	25,5	24	22,5	20,5	19		
B-NM 50/200B/C	NM 50/20B/C	9,2	12,5			48	47,5	47,5	47	45,5	44,5	42,5	40	37	33	30,5	28	25,5	23		
B-NM 50/200A/C	NM 50/20A/C	11	15			55	55	54,5	54,5	53,5	52	50	48	45	41,5	39,5	37	35	32,5		
B-NM 50/200S/C	NM 50/20S/C	15	20			60	60	59,5	59,5	58,5	57,5	55,5	53,5	50,5	47	45	43	40,5	37		
B-NM 5025/C/C	NM 50/25C/C	11	15			55	54,5	54	53	51,5	49,5	46	41,5	35,5	28,5	24,5					
B-NM 5025/B/C	NM 50/25B/C	15	20			69	68,5	68	67,5	66	64	61	57	52,5	46,5	43					
B-NM 5025/A/C	NM 50/25A/C	18,5	25			80,5	80,5	80	79,5	78,5	77	74,5	71,5	67	61,5	58,5					

B-NM - B-NMS	NM - NMS	P ₂		Q m³/h	37,8	42	48	54	60	66	75	84	96	108	120	132	141	150	
		kW	HP		l/min	630	700	800	900	1000	1100	1250	1400	1600	1800	2000	2200	2350	2500
B-NM 65/125E/A	NM 65/12E/C	4	5,5	H m	16,5	16,4	16,2	15,9	15,5	15,1	14,3	13,2	11,4	9,2					
B-NM 65/125C/B	NM 65/12C/B	5,5	7,5		21,1	21	20,8	20,6	20,3	19,9	19,1	18,2	16,5	14,4	11,8				
B-NM 65/125A/B	NM 65/12A/B	7,5	10		25,9	25,8	25,6	25,4	25,1	24,8	24,1	23,3	21,9	20	17,6				
B-NM 65/160D/B	NM 65/16D/B	7,5	10				24,3	24,1	23,9	23,6	23,1	22,3	20,8	18,8	16,3				
B-NM 65/160C/C	NM 65/16C/C	9,2	12,5				28,1	28,0	27,8	27,6	27,1	26,3	24,9	23,1	20,7	17,7			
B-NM 65/160B/C	NM 65/16B/C	11	15				32,6	32,5	32,3	32	31,5	30,8	29,5	27,9	25,7	23,0			
B-NM 65/160AR	NM 65/16AR	15	20				36,4	36,3	36,2	35,9	35,5	34,8	33,7	32,1	30,0	27,5			
B-NM 65/160A/C	NM 65/16A/C	15	20				40,5	40,4	40,2	40	39,5	38,8	37,6	36,1	34,2	31,7			
B-NM 65/200C/C	NM 65/20C/C	15	20				44	43,8	43,5	43,1	42,3	41,2	39,4	37,1	34,4	31,4	28,8		
B-NM 65/200B/C	NM 65/20B/C	18,5	25				50,5	50,4	50,2	49,9	49,2	48,3	46,8	44,8	42,5	39,8	37,5		
B-NM 65/200A/B	NM 65/20A/B	22	30				57	57	57	56,5	56	55,5	54	52,5	50	47,5	45,5		
B-NM 65/250C/B	NM 65/25C/A	22	30				61	61	60,5	60	58,5	57	54,5	51,5	47,5	43			
B-NMS 65/250B/A	NMS 65/250B/A	30	40				73,5	73,5	73,5	73,5	73	71,5	69,5	66,5	63	59			
B-NMS 65/250A/B	NMS 65/250A/B	37	50				86,5	86,5	87	86,5	86	85,5	83,5	81	78	74,5			

Performance n ≈ 2900 rpm

B-NM - B-NMS	NM - NMS	P ₂		Q m ³ /h l/min	H m															
		kW	HP		75	84	96	108	120	132	150	168	180	192	210	240	270	300		
					1250	1400	1600	1800	2000	2200	2500	2800	3000	3200	3500	4000	4500	5000		
B-NM 80/160E/B	NM 80/16E/B	7,5	10	21,5	20,9	19,9	18,7	17,4	15,9	13,4	10,6									
B-NM 80/160D/C	NM 80/16D/C	9,2	12,5	25,2	24,5	23,5	22,4	21,1	19,6	17,2	14,4									
B-NM 80/160C/C	NM 80/16C/C	11	15	28,7	28,2	27,4	26,4	25,1	23,8	21,3	18,5	16,4								
B-NM 80/160B/C	NM 80/16B/C	15	20	34,8	34,5	33,8	33	32,1	30,9	28,9	26,4	24,5	22,4							
B-NM 80/160A/C	NM 80/16A/C	18,5	25	39,9	39,6	39	38,2	37,4	36,4	34,5	32,2	30,3	28,1							
B-NMS 80/200B/A	NM 80/20B	22	30	46,5	46	45,5	44,5	43,5	42	39*	35,5*	32*								
B-NMS 80/200A/A	NMS 80/200A	30	40	56	55,5	55	54	53	52	49,5*	46*	43*								
B-NMS 80/250E/A	NM 80/25E	22	30	51	50	48,5	46,5	44,5	42	38*	33*	29*								
B-NMS 80/250D/A	NMS 80/250D	30	40	65	64	62,5	61	59	56,5	53*	49*	45,5*	41*							
B-NMS 80/250C/A	NMS 80/250C/A	37	50	73,5	73	72	70,5	69	67	63*	59*	55,5*	51,5*							
B-NMS 80/250B/A	NMS 80/250B/A	45	60	84	83,5	82,5	81,5	80	78	74,5*	70,5*	67*	63*							
B-NMS 80/250A/A	NMS 80/250A/A	55	75	95	94,5	93,5	92,5	91,5	90	87,5*	84*	80,5*	76,5*							
B-NMS 100/200E/A	NM 100/20E	18,5	25				30	29,5	29	28	27	26	25	23	19*					
B-NMS 100/200D/A	NM 100/20D	22	30				36	35,5	35	34	33	32	31	29	24,5*	19*				
B-NMS 100/200C/A	NMS 100/200C	30	40				45	44,5	44	43,5	42,5	41,5	40,5	39	34,5*	29*	22°			
B-NMS 100/200B/A	NMS 100/200B/A	37	50				54	53,5	53	52,5	51,5	50,5	49,5	48	44*	38,5*	32°			
B-NMS 100/200A/A	NMS 100/200A/A	45	60				61,5	61	60,5	60	59,5	58,5	58	56,5	53*	48*	42°			
B-NMS 100/250B/A	NMS 100/250B/A	55	75				73,5	73	72,5	71,5	70	68,5	67	65	61*	55,5*	48,5°			
B-NMS 100/250A/A	NMS 100/250A/A	75	100				91	90,5	90	89,5	88,5	88	87	85	81*	75*	67°			

NM(S) Standard construction.
B-NM(S) Bronze construction.

P₂ Rated motor power output.
H Total head in m.

* Maximum suction lift 1-2 m.
◦ With 1 m suction head.

Tolerances according to UNI EN ISO 9906:2012

Rated currents

P ₂		230V Δ / 400V Y 400V Δ / 690V Y			I _A /I _N
kW	HP	I _N A	I _N A	I _N A	
0,55	0,75	4	2,3		4,8
0,75	1	4	2,3		6,1
1,1	1,5	4,6	2,7		5,5
1,5	2	7,5	4,3		6,1
2,2	3	9,2	5,3		8,4
3	4	11,5	6,6		8,2
4	5,5		9,6	5,5	8,9
5,5	7,5		10,8	6,2	9,1
7,5	10		14,3	8,3	9,1
9,2	12,5		18,5	10,7	8,2
11	15		21,5	12,4	8,5
15	20		27,3	15,8	9,5
18,5	25		34	19,6	9,5
22	30		41	23,7	9,5
30	40		54	31,2	8,8
37	50		64	36,9	7,2
45	60		77	44,5	7,3
55	75		93	53,7	6,8
75	100		128	73,9	7

P₂ Rated motor power output.
I_A/I_N D.O.L. starting current / Nominal current

Characteristic curves $n \approx 2900$ rpm

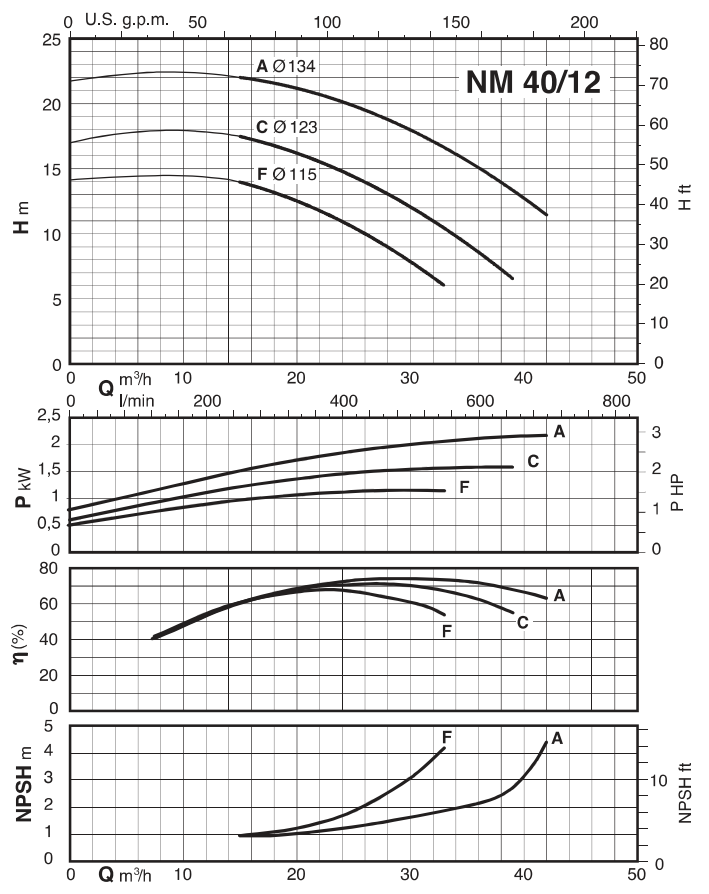
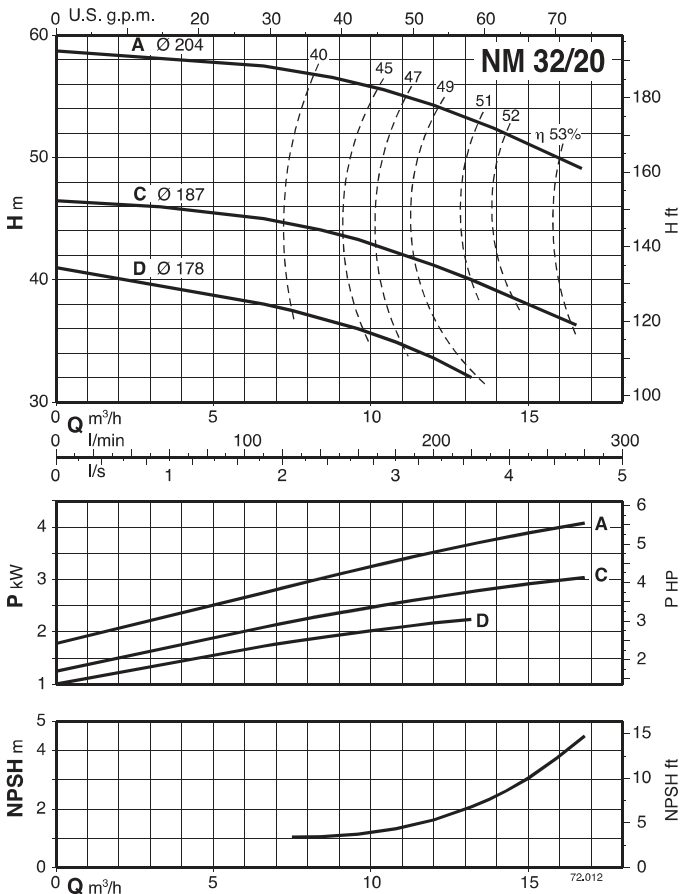
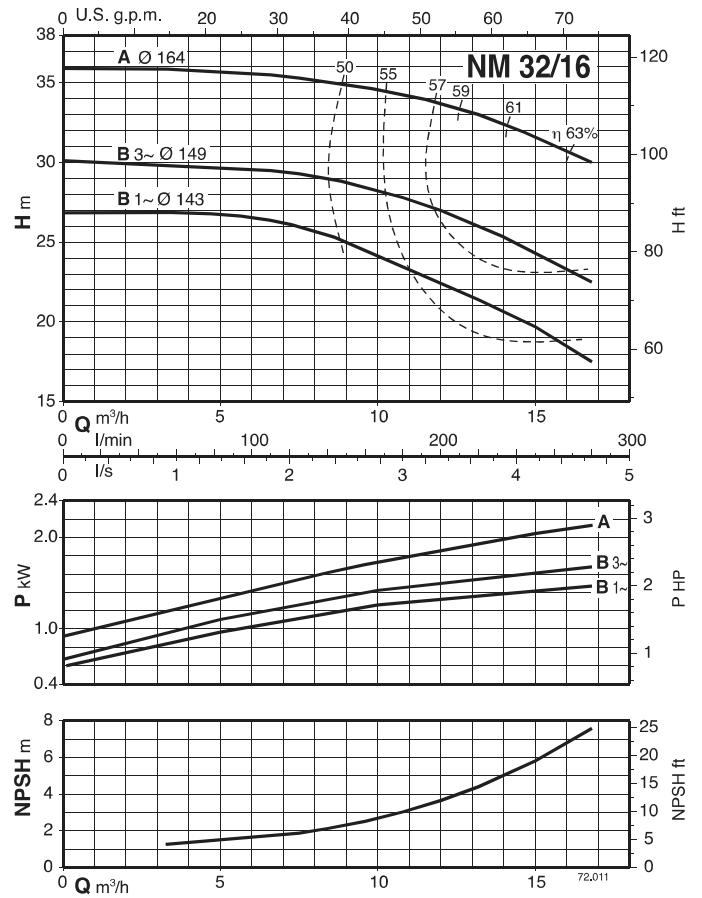
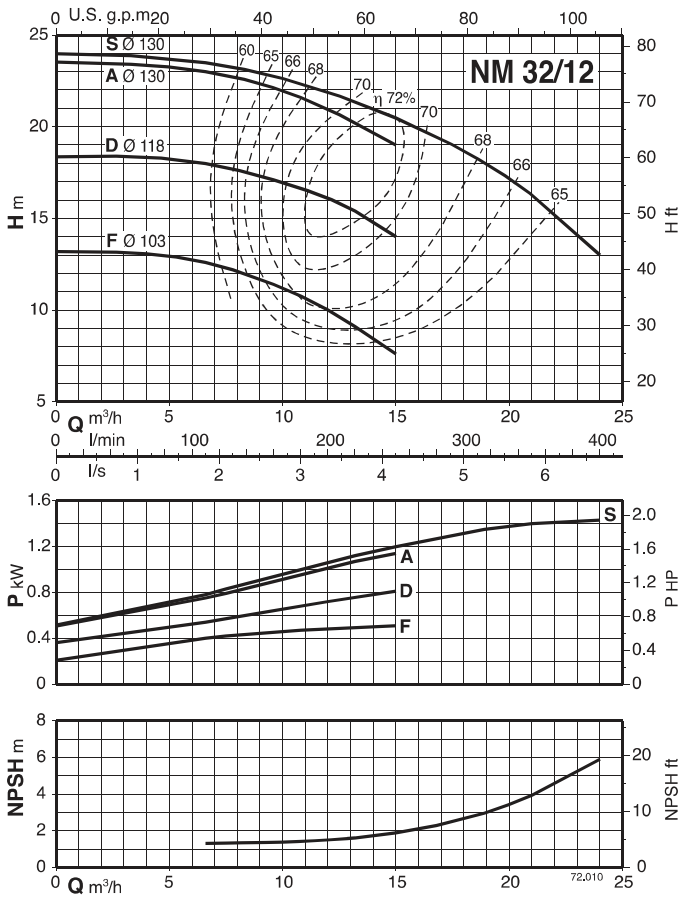

Characteristic curves $n \approx 2900$ rpm

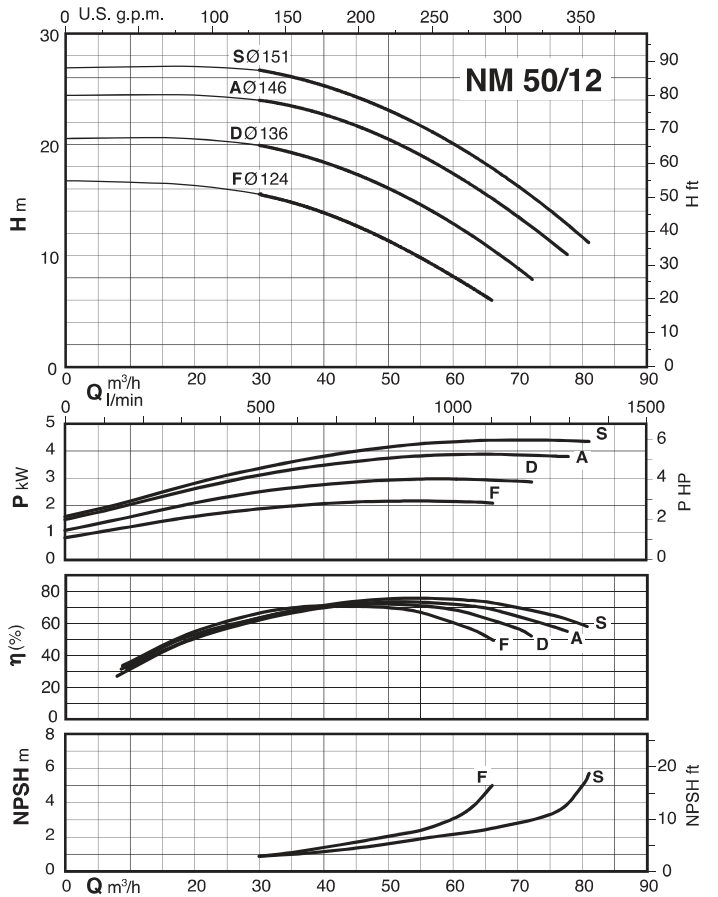
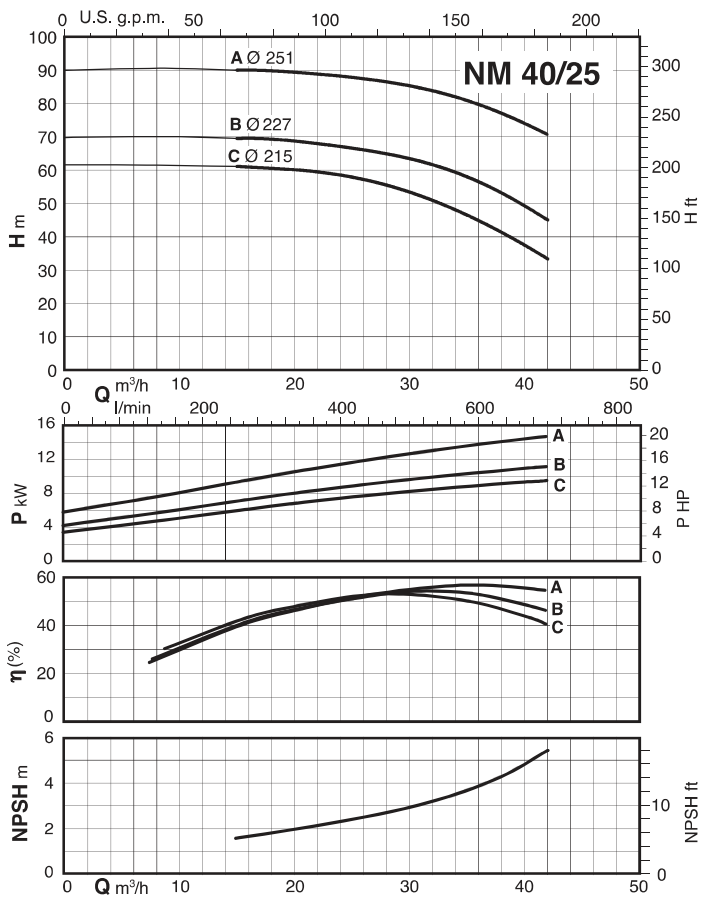
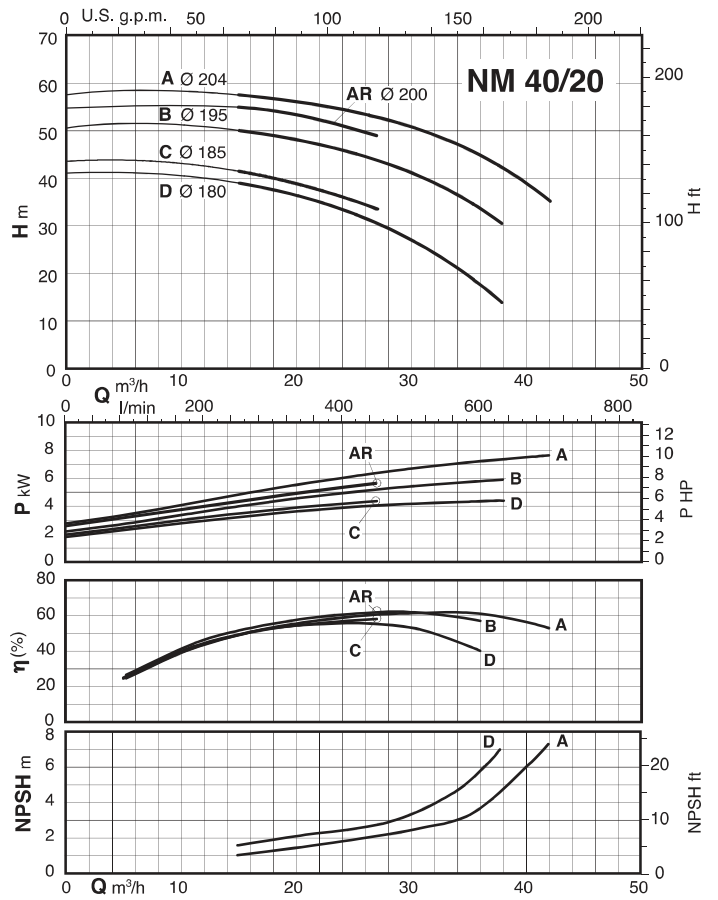
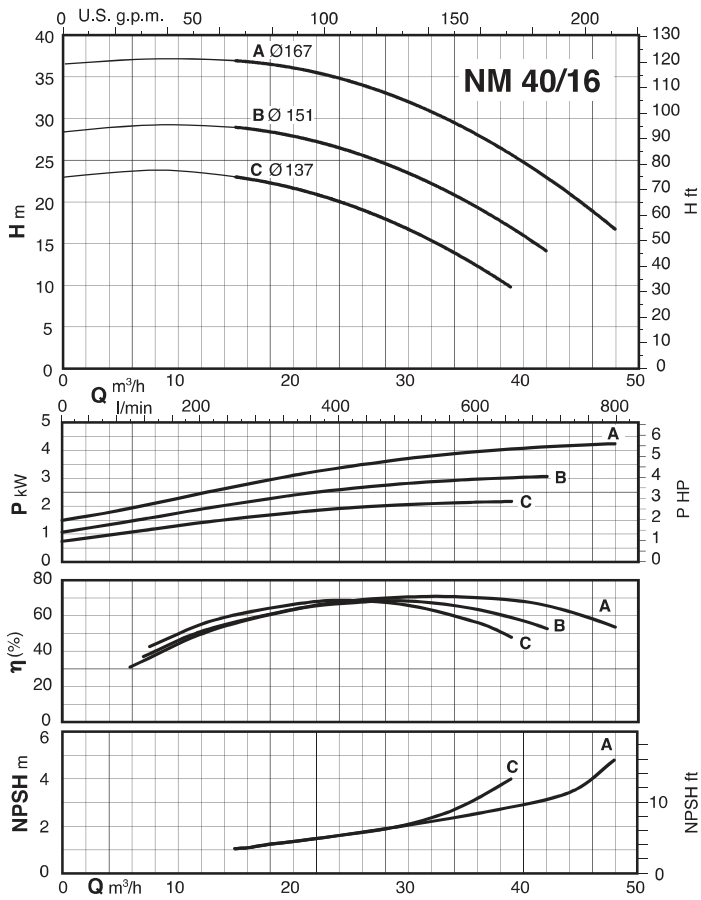

Characteristic curves $n \approx 2900$ rpm

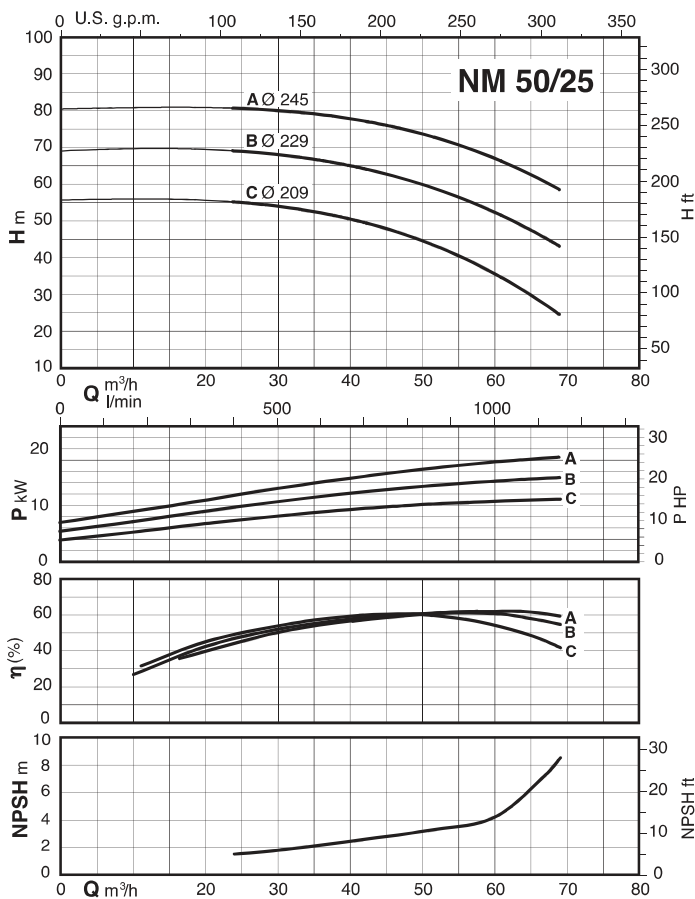
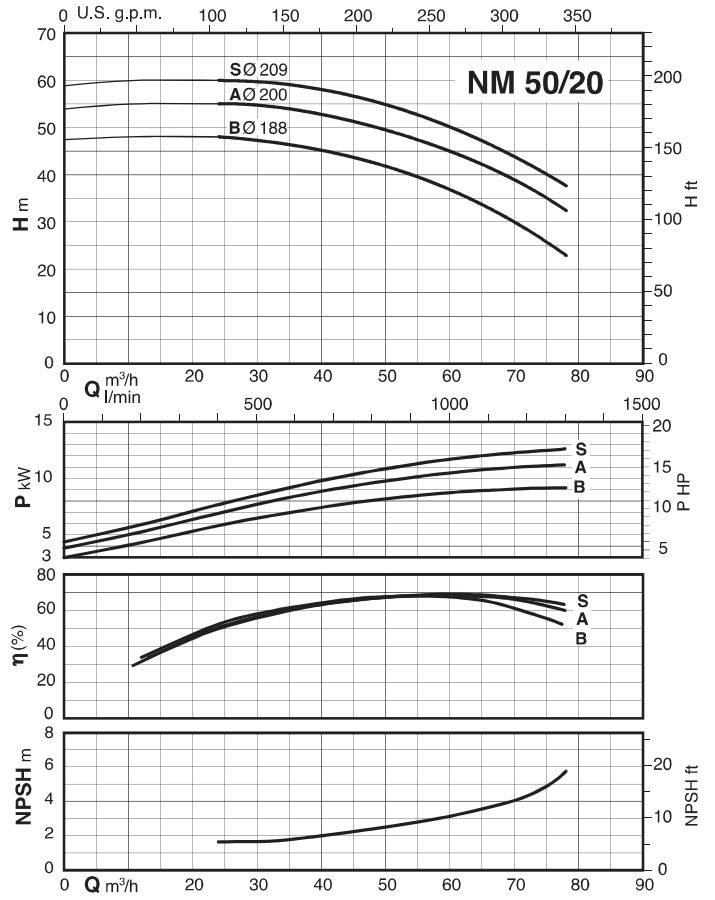
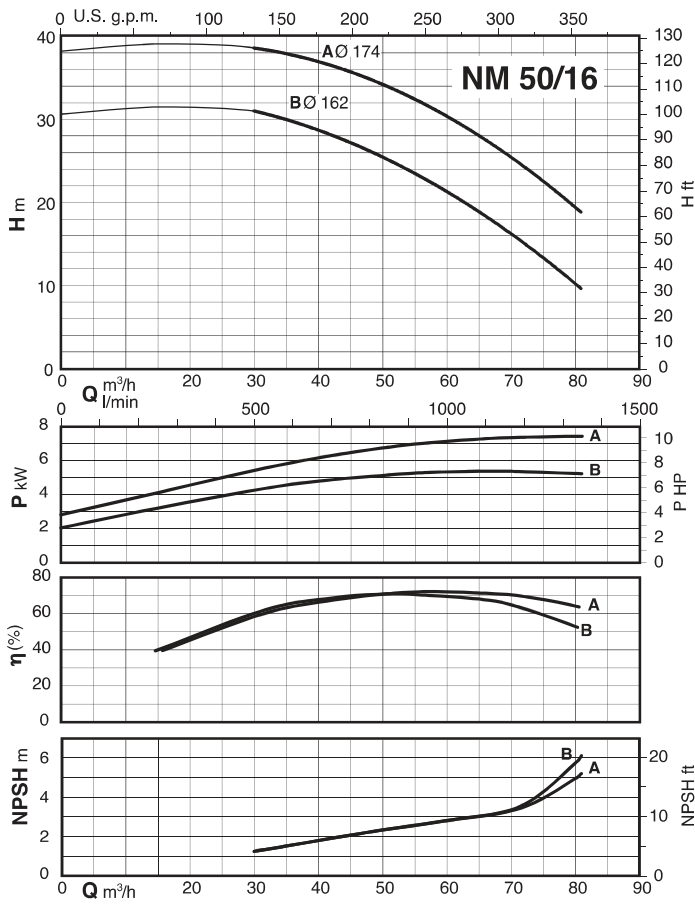

Characteristic curves $n \approx 2900$ rpm

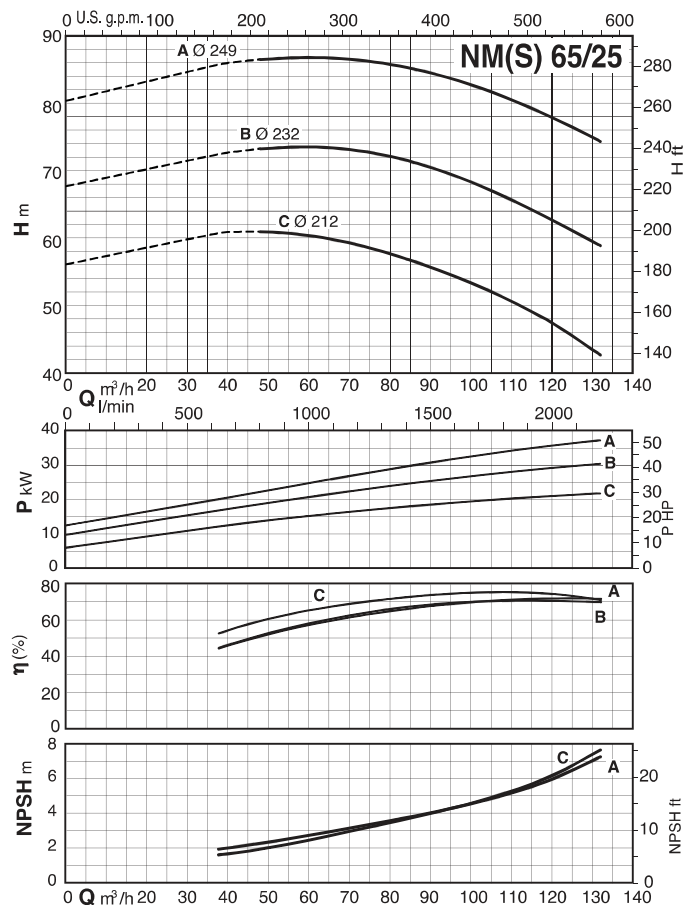
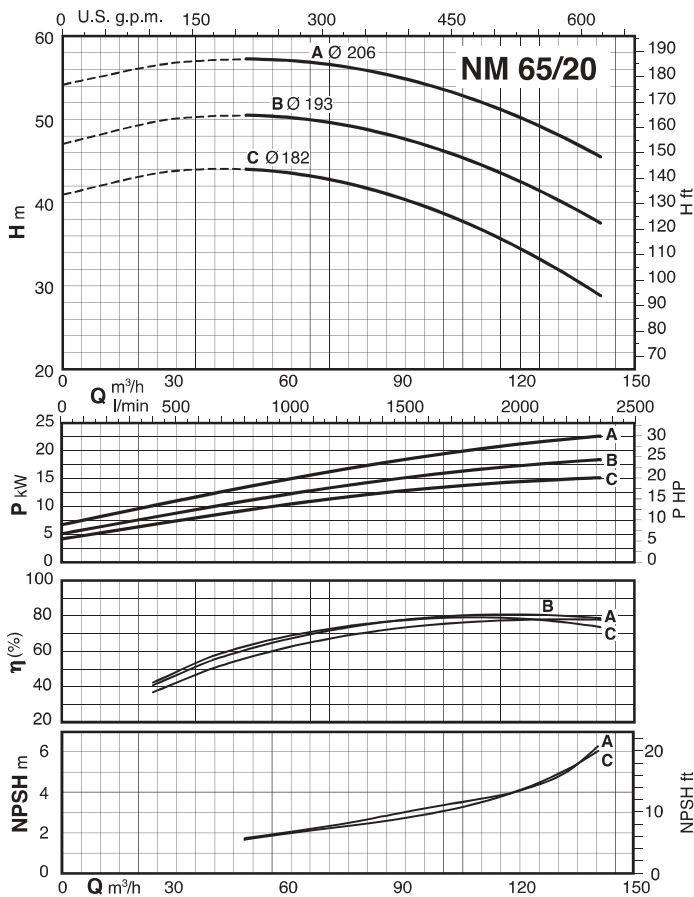
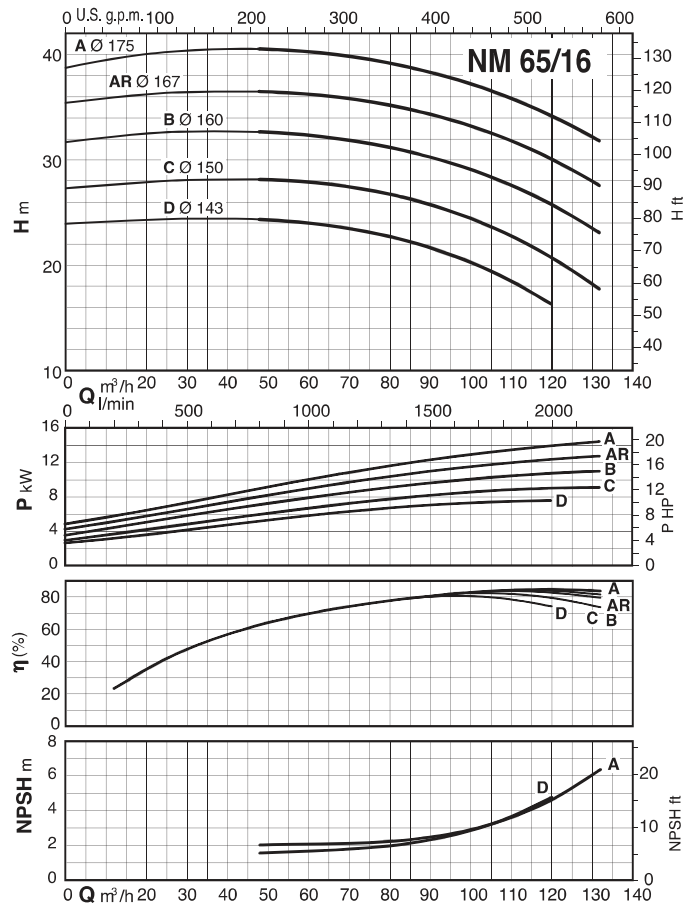
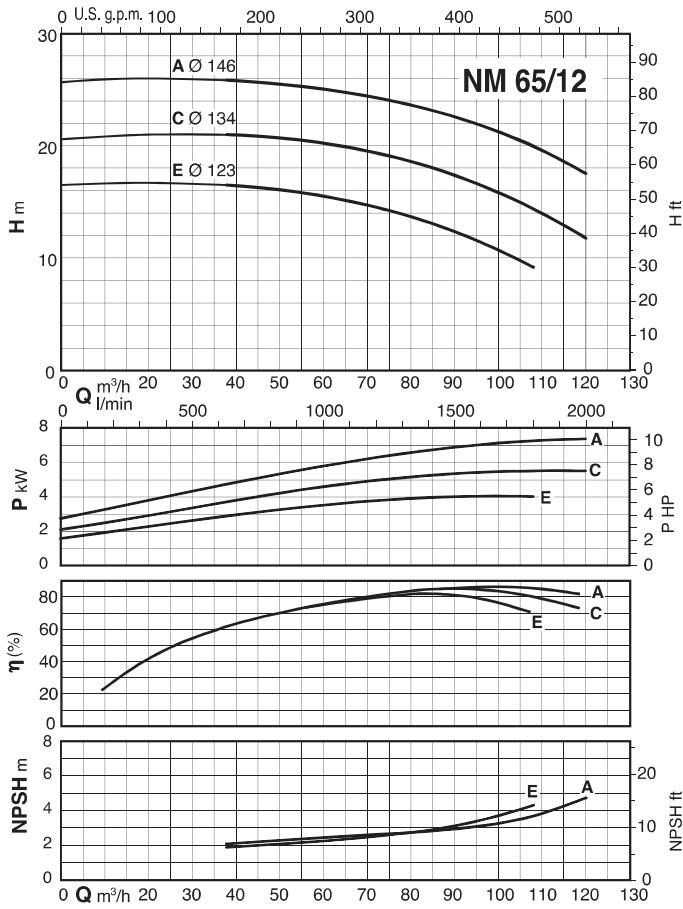

Characteristic curves $n \approx 2900$ rpm

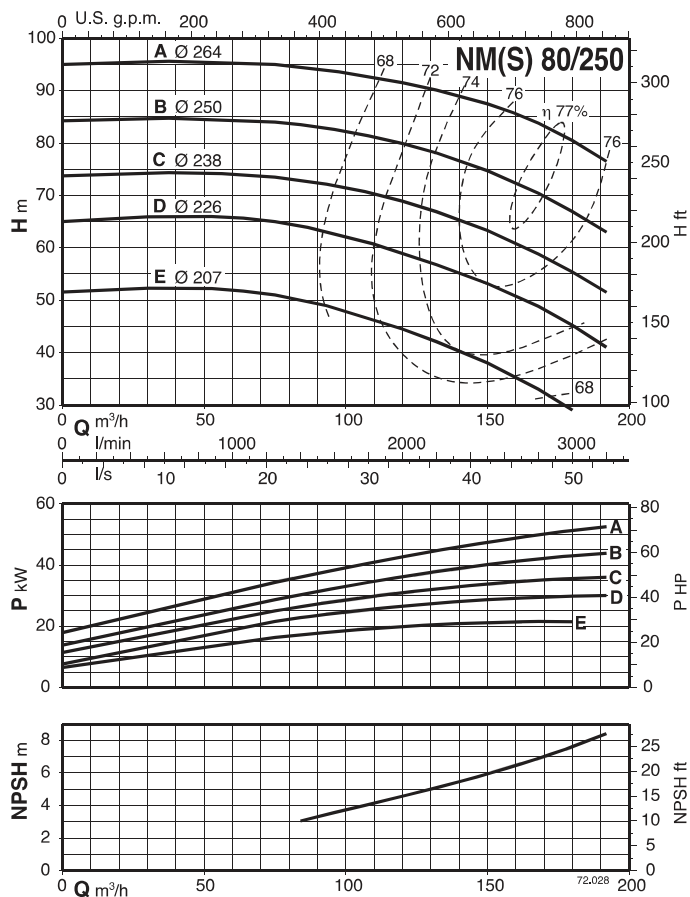
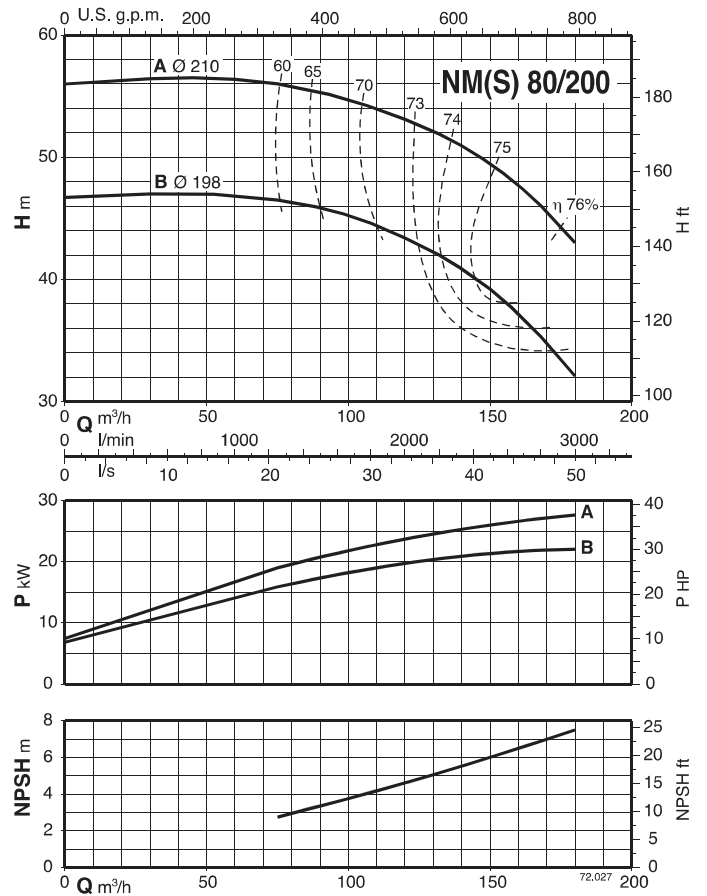
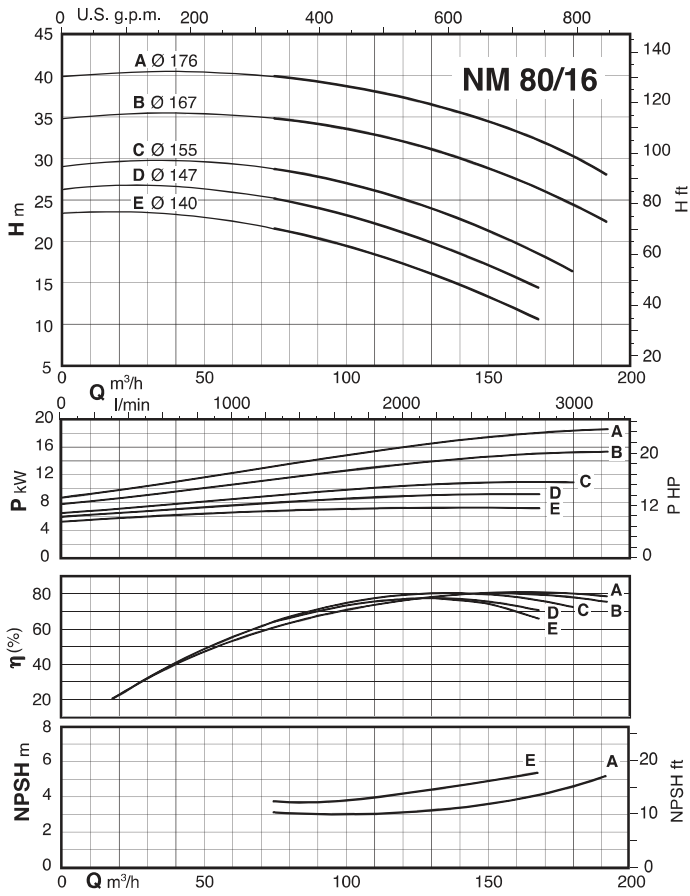

Characteristic curves $n \approx 2900$ rpm

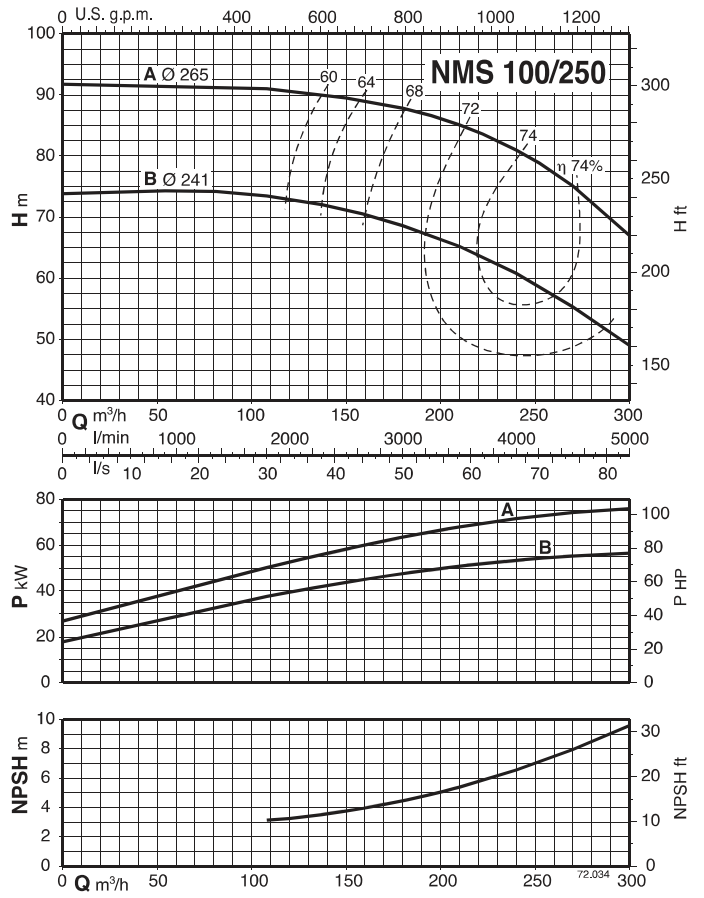
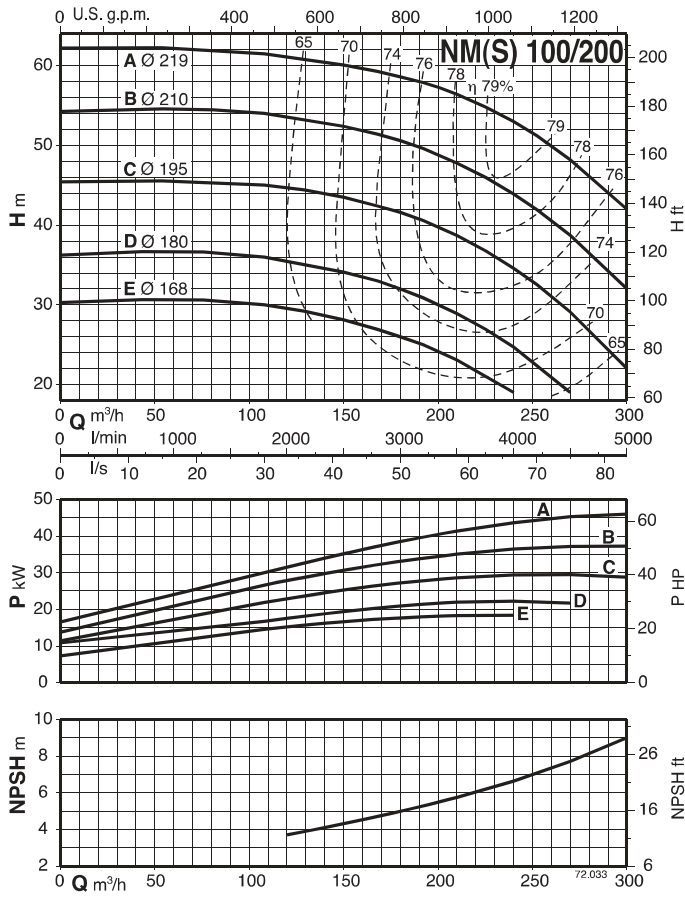

Dimensions and weights

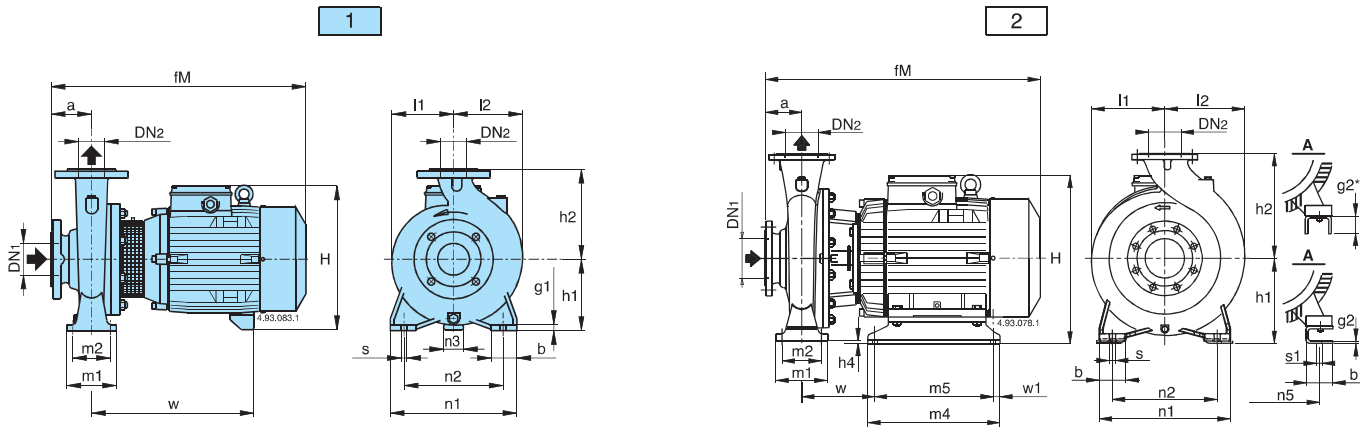

Picture	NM	mm																				kg																											
		DN1	DN2	a	fM	h1	h2	H	h4	m1	m2	n1	n2	n3	n5	w1	b	b1	s	s1	l1		l2	w	m4	m5	g1	g2																					
1	NM 32/12DE-FE NM 32/12S/A-A/A	50	32	80	405	112	140	240	-	100	70	190	140	37	-	-	50	-	14	-	93	97	245	-	-	12	-	24-24 27-26																					
	NM 32/16B/A NM 32/16A/B	50	32	80	410 450	132	160	260	-	100	70	240	190	47	-	-	50	-	14	-	120	120	250 290	-	-	12	-	34 39																					
	NM 32/20D/B NM 32/20C/A NM 32/20A/B	50	32	80	450 475 475	160	180	288 298 298	-	100	70	240	190	62 60 60	-	-	50	-	14	-	140	140	290 295 295	-	-	12	-	42 47 51																					
	NM 40/12C/B-F/B NM 40/12A/C	65	40	80	410 450	112	140	240	-	100	70	210	160	37	-	-	50	-	14	-	100	113	250 290	-	-	12	-	29-27 32																					
	NM 40/16C/C NM 40/16B/B NM 40/16A/C	65	40	80	450 475 475	132	160	260 270 270	-	100	70	240	190	47 45 45	-	-	50	-	14	-	121	122	290 295 295	-	-	10	-	39 46 48																					
	NM 40/20C/B-D/B NM 40/20A/A-AR/A-B/A	65	40	100	495 525	160	180	298 320	-	100	70	265	212	60 49	-	-	50	-	14	-	142	142	295 320	-	-	12	-	54-53 73-67-67																					
	NM 40/25C/C NM 40/25B/C NM 40/25A/C	65	40	100	640 690 715	180	225	365	-	125	95	320	250	50	-	-	65	-	14	-	175	175	400 460 460	-	-	15	-	108 117 139																					
	NM 50/12F/C NM 50/12D/B NM 50/12A/C-S/C	65	50	100	470 495 495	132	160	260 270 270	-	100	70	240	190	47 45 45	-	-	50	-	14	-	122	137	290 295 295	-	-	10	-	40 47 50,5-50,6																					
	NM 50/16A/B-B/B	65	50	100	525	160	180	320	-	100	70	265	212	49	-	-	50	-	14	-	126	140	320	-	-	12	-	70,5-64																					
	NM 50/20B/C NM 50/20A/C NM 50/20S/C	65	50	100	640 690 720	160	200	345	-	100	70	265	212	40	-	-	50	-	14	-	140	153	400 460 460	-	-	15	-	100 109 131																					
	NM 50/25C/C NM 50/25B/C NM 50/25A/C	65	50	100	695 720 720	180	225	365	-	125	95	320	250	50	-	-	65	-	14	-	175	175	465 465 465	-	-	15	-	122 145 151																					
	NM 65/12E/C NM 65/12A/B-C/B	80	65	100	500 530	160	180	298 320	-	125	95	280	212	60 49	-	-	65	-	14	-	130	154	300 325	-	-	12	-	51,9 70,7-64,7																					
	NM 65/16D/B NM 65/16C/C NM 65/16B/C NM 65/16A/C-AR	80	65	100	525 640 690 715	160	200	320 345 345 345	-	125	95	280	212	49 40 40 40	-	-	65	-	14	-	140	161	320 410 410 460	-	-	12	-	70,5 93 112 127																					
	NM 65/20C/C NM 65/20B/C	80	65	100	715	180	225	365	-	125	95	320	250	50	-	-	65	-	14	-	159	179	460	-	-	12	-	134 140																					
	2	NM 65/20A/A	80	65	100	762	202	225	408	22	125	95	320	250	-	254	20	65	90	14	14	159	179	182	400	360	-	42*	172																				
		NM 65/25C/A	80	65	100	762	202	250	408	2	160	120	360	280	-	254	20	80	90	18	14	179	185	182	400	360	-	42*	187																				
	1	NM 80/16E/B NM 80/16D/C	100	80	125	545 670	180	225	340 365	-	125	95	320	250	60 50 50 50	-	-	65	-	14	-	153	181	320 415 465 465	-	-	12	-	77,5 101 120 132 138																				
		NM 80/16C/C NM 80/16B/C NM 80/16A/C				720 745 745			365 365 365															415 465 465					101 120 132 138																				
		NM 80/20B				787			202															250					408	22	125	95	345	280	-	254	20	65	90	18	14	170	194	182	400	360	-	42*	180
		NM 80/25E				787			202															280					408	2	160	120	400	315	-	254	20	80	90	18	14	191	210	182	400	360	-	42*	193
NM 100/20E		125				100			125															739					200	280	386	-	160	120	360	280	60	-	-	80	-	18	-	180	212	458	-	-	21
2	NM 100/20D	125	100	125	787	202	280	408	2	160	120	360	280	-	254	20	80	90	18	14	180	212	182	400	360	-	42*	189																					

° Version without coupling guard

Pumps with packed gland, dimensions available on request (excluded NMS).

Dimensions and weights

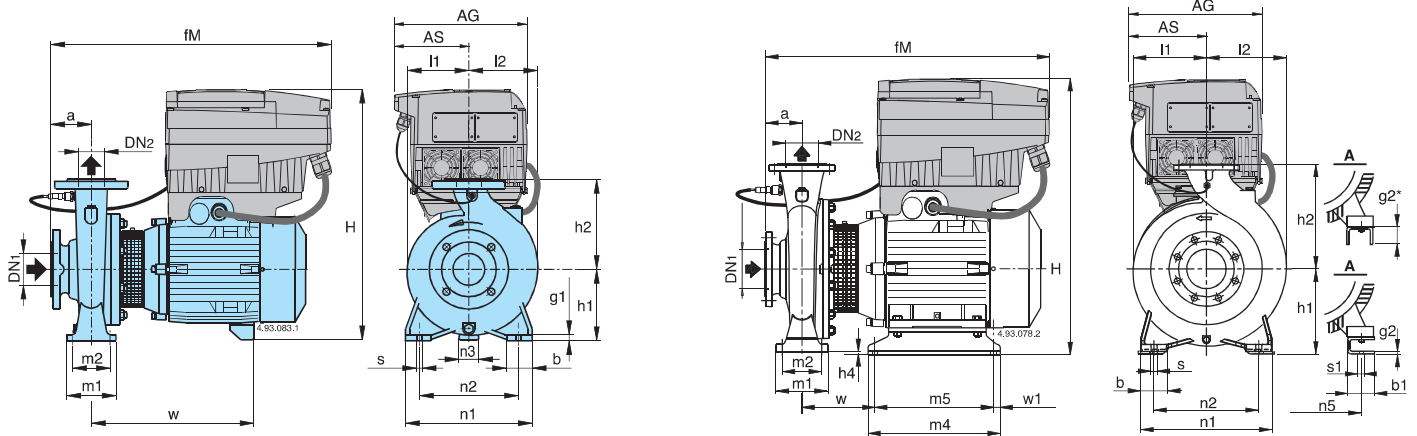

Picture	NM EI	mm																								kg						
		DN1	DN2	a	fM	AG	AS	h1	h2	H	h4	m1	m2	n1	n2	n3	n5	w1	b	b1	s	s1	I1	I2	w		m4	m5	g1	g2		
1	NM EI 32/12DE-FE NM EI 32/12S/A-A/A	50	32	80	435	190	105	112	140	398	-	100	70	190	140	37	-	-	50	-	14	-	93	97	245	-	-	12	-	30,4-30,4 32,4-33,4		
	NM EI 32/16B/A NM EI 32/16A/B	50	32	80	440 470	190 210	105 118	132	160	418	-	100	70	240	190	47	-	-	50	-	14	-	120	120	250 290	-	-	12	-	40,4 46,5		
	NM EI 32/20D/B NM EI 32/20C/A NM EI 32/20A/B	50	32	80	470 485 485	210	118	160	180	446 454 454	-	100	70	240	190	62 60 60	-	-	50	-	14	-	140	140	290 295 295	-	-	12	-	49,5 54,5 59		
	NM EI 40/12C/B-F/B NM EI 40/12A/C	65	40	80	440 470	190 210	105 118	112	140	398	-	100	70	210	160	37	-	-	50	-	14	-	100	113	250 290	-	-	12	-	33,4-35,4 39,5		
	NM EI 40/16C/C NM EI 40/16B/B NM EI 40/16A/C	65	40	80	470 485 485	210	118	132	160	418 426 426	-	100	70	240	190	47 45 45	-	-	50	-	14	-	121	122	290 295 295	-	-	10	-	46,5 53,5 56		
	NM EI 40/20C/B-D/B NM EI 40/20AR/A-B/A NM EI 40/20A/A	65	40	100	505 525 535	210 281 281	118 153 153	160	180	454 482 528	-	100	70	265	212	60 49 49	-	-	50	-	14	-	142	142	295 320 320	-	-	12	-	61-62 75-75 87,8		
	NM EI 40/25C/C NM EI 40/25B/C NM EI 40/25A/C	65	40	100	640 690 738	281 281 350	153 153 190	180	225	573 573 651	-	125	95	320	250	50	-	-	65	-	14	-	175	175	400 460 460	-	-	15	-	122,8 131,8 166,8		
	NM EI 50/12F/C NM EI 50/12D/B NM EI 50/12A/C-S/C	65	50	100	490 505 505	210	118	132	160	418 426 426	-	100	70	240	190	47 45 45	-	-	50	-	14	-	122	137	290 295 295	-	-	10	-	47,5 54,5 57-57		
	NM EI 50/16B/B NM EI 50/16A/B	65	50	100	525 535	281	153	160	180	482 528	-	100	70	265	212	49	-	-	50	-	14	-	126	140	320	-	-	12	-	72 85,3		
	NM EI 50/20B/C NM EI 50/20A/C NM EI 50/20S/C	65	50	100	640 690 738	281 281 350	153 153 190	160	200	553 553 631	-	100	70	265	212	40	-	-	50	-	14	-	140	153	400 460 460	-	-	15	-	114,8 123,8 166		
	NM EI 50/25C/C NM EI 50/25B/C NM EI 50/25A/C	65	50	100	695 743 743	281 350 350	153 190 190	180	225	533 651 651	-	125	95	320	250	50	-	-	65	-	14	-	175	175	465 465 465	-	-	15	-	136,8 180 186		
	NM EI 65/12E/C NM EI 65/12C/B NM EI 65/12A/B	80	65	100	510 530 540	210 281 281	118 153 153	160	180	482 528 528	-	125	95	280	212	60 49 49	-	-	65	-	14	-	130	154	300 325 325	-	-	12	-	59,9 72,7 85,5		
	NM EI 65/16D/B NM EI 65/16C/C NM EI 65/16B/C NM EI 65/16A/C-AR	80	65	100	525 640 690 738	281 281 281 350	153 153 153 190	160	200	582 553 553 631	-	125	95	280	212	49 40 40 40	-	-	65	-	14	-	140	161	320 410 410 460	-	-	12	-	85,3 107,8 126,8 162		
	NM EI 65/20C/C NM EI 65/20B/C	80	65	100	738	350	190	180	225	651	-	125	95	320	250	50	-	-	65	-	14	-	159	179	460	-	-	12	-	171 176		
	2	NM EI 65/20A/A	80	65	100	765	350	190	202	225	693	22	125	95	320	250	-	254	20	80	90	14	14	155	175	182	400	360	-	42°	207	
		NM EI 65/25C/A	80	65	100	765	350	190	202	250	693	2	160	120	360	280	-	254	20	80	90	18	14	179	185	182	400	360	-	42°	222	
	1	NM EI 80/16E/B NM EI 80/16D/C NM EI 80/16C/C NM EI 80/16B/C NM EI 80/16A/C	100	80	125	555 670 720 768 768	281 281 350 350 350	153 153 190 190 190	180	225	548 573 573 651 651	-	125	95	320	250	60 50 50 50 50	-	-	65	-	14	-	165	193	320 415 415 465 465	-	-	15	-	92,3 115,8 134,8 167 173	
		2	NM EI 80/20B	100	80	125	790	350	190	202	250	693	22	125	95	345	280	-	254	20	80	90	18	14	170	194	182	400	360	-	42°	215
			NM EI 80/25E	100	80	125	790	350	190	202	280	693	2	160	120	400	315	-	254	20	80	90	18	14	191	210	182	400	360	-	42°	228
		1	NM EI 100/20E	125	100	125	763	350	190	200	280	671	-	160	120	360	280	60	-	-	80	-	18	-	180	212	458	-	-	21	-	197
		2	NM EI 100/20D	125	100	125	790	350	190	202	280	693	2	160	120	360	280	-	254	20	80	90	18	14	180	212	182	400	360	-	42°	224

Dimensions and weights

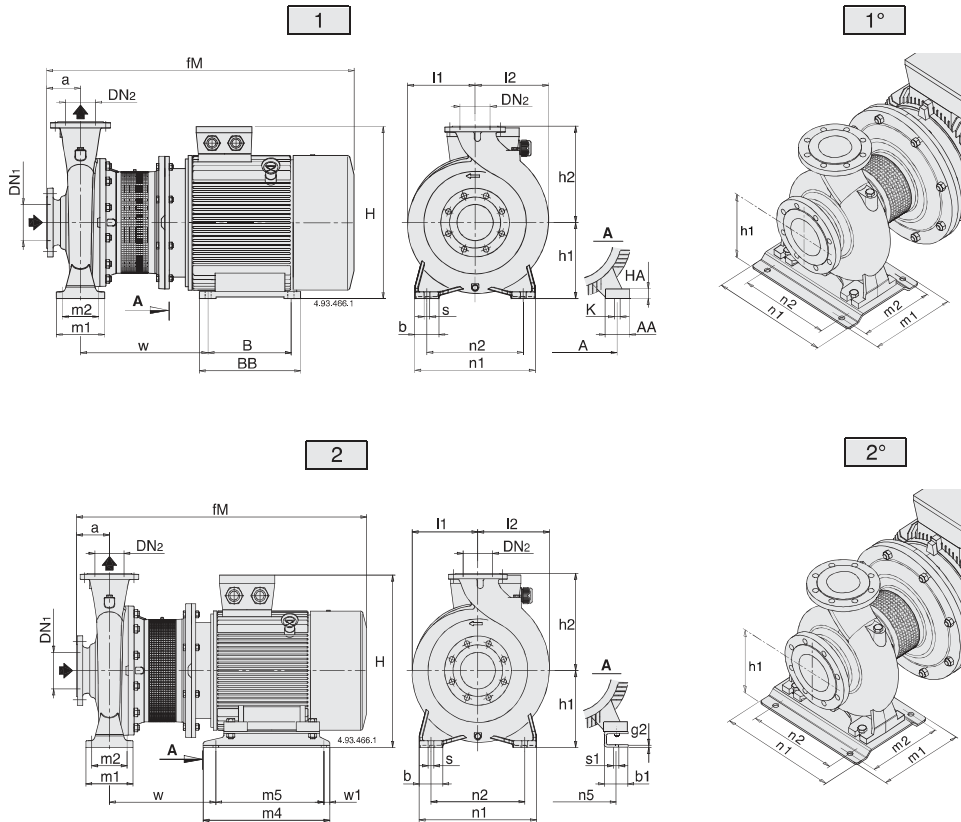

Picture	NMS	mm																										kg				
		DN1	DN2	a	fM	h1	h2	H	m1	m2	n1	n2	A	n5	w1	b	AA	b1	s	K	s1	l1	l2	w	BB	m4	B		m5	HA	g2	
2	NMS 65/250B/A	80	65	100	961	200	250	486	160	120	360	280	-	279	20	80	-	70	18	-	15	179	195	333	-	440	-	400	-	20	269	
1	NMS 65/250A/B	80	65	100	1009	200	250	515	160	120	360	280	318	-	-	80	70	-	18	19	-	200	200	406	355	-	305	-	25	-	321	
1	NMS 80/200A	100	80	125	986	180	250	466	125	95	345	280	279	-	-	65	65	-	14	19	-	170	194	394	328	-	279	-	20	-	256	
2	NMS 80/250D	100	80	125	986	200	280	486	160	120	400	315	-	279	20	80	-	70	18	-	15	191	211	333	-	440	-	400	-	20	276	
1	NMS 80/250C/A	100	80	125	1034	200	280	515	160	120	400	315	318	-	-	80	70	-	18	19	-	200	210	406	355	-	305	-	25	-	345	
1°	NMS 80/250B/A	100	80	125	1129	225	280	563	298	258	410	315	356	-	-	-	-	-	18	19	-	225	225	445	361	-	311	-	34	-	437	
2°	NMS 80/250A/A	100	80	125	1198	280	280	690	260	220	410	315	-	406	25	-	-	100	18	-	24	275	275	443	-	500	-	450	-	8	534	
2	NMS 100/200C	125	100	125	986	200	280	486	160	120	360	280	-	279	20	80	-	70	18	-	15	180	212	333	-	440	-	400	-	20	270	
1	NMS 100/200B/A	125	100	125	1034	200	280	515	160	120	360	280	318	-	-	80	70	-	18	19	-	200	212	406	355	-	305	-	25	-	338	
1°	NMS 100/200A/A	125	100	125	1129	225	280	563	298	258	410	315	356	-	-	-	-	80	-	18	19	-	225	225	445	361	-	311	-	34	-	426
2°	NMS 100/250B/A	125	100	140	1213	280	280	690	260	220	410	315	-	440	25	-	-	100	18	-	24	275	275	443	-	500	-	450	-	8	545	
1°	NMS 100/250A/A	125	100	140	1286	280	280	713	260	220	410	315	457	-	-	-	-	100	-	18	24	-	275	275	516	479	-	368	-	40	-	648

Flanges EN 1092-2

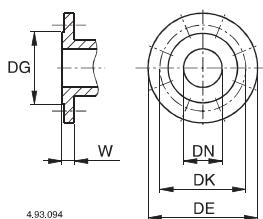

4.93.094

mm						
DN	DG	DK	DE	Holes		W
				N°	Ø	
32	76	100	140	4	19	18
40	84	110	150	4	19	18
50	99	125	165	4	19	20
65	118	145	185	4	19	20
80	132	160	200	8	19	22
100	156	180	220	8	19	24
125	184	210	250	8	19	24

Dimensions and weights

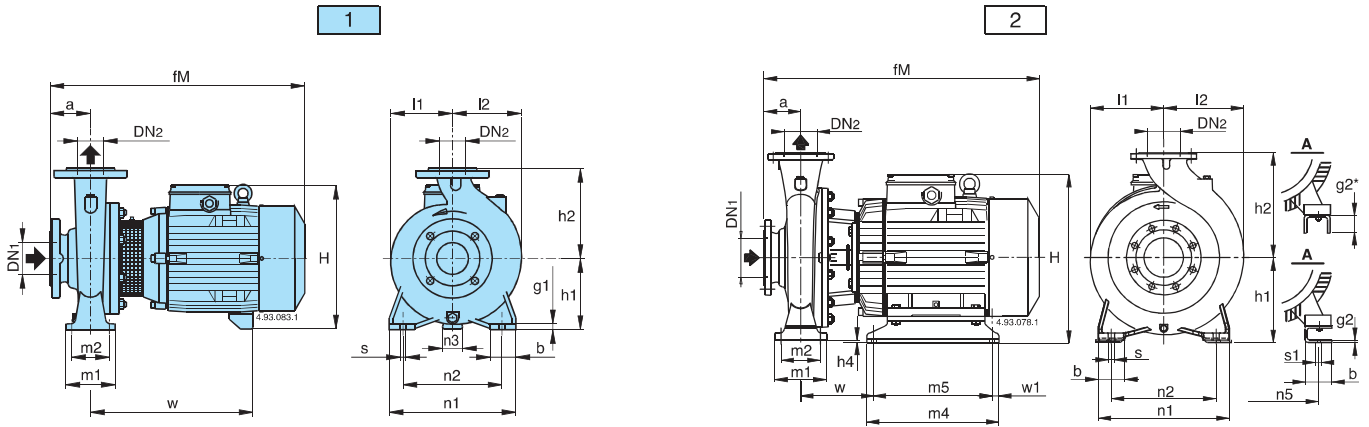

Picture	B- NM	mm																						kg				
		DN1	DN2	a	fM	h1	h2	H	h4	m1	m2	n1	n2	n3	n5	w1	b	b1	s	s1	l1	l2	w	m4	m5	g1	g2	B-NM
1	B-NM 32/12D-F B-NM 32/12S/A-A/A	50	32	80	405	112	140	240	-	100	70	190	140	37	-	-	50	-	14	-	93	97	245	-	-	12	-	27-27 30-28
	B-NM 32/16B/A B-NM 32/16A/B	50	32	80	410 450	132	160	260	-	100	70	240	190	47	-	-	50	-	14	-	120	120	250 290	-	-	12	-	38,5 42
	B-NM 32/20D/B B-NM 32/20C/A B-NM 32/20A/B	50	32	80	450 475 475	160	180	288 298 298	-	100	70	240	190	45 60 60	-	-	50	-	14	-	140	140	290 295 295	-	-	12	-	47,5 56,5 58
	B-NM 40/12C/A-F/A B-NM 40/12A/B	65	40	80	410 450	112	140	240	-	100	70	210	160	37	-	-	50	-	14	-	100	113	250 290	-	-	12	-	33-31 36
	B-NM 40/16C/B B-NM 40/16B/A B-NM 40/16A/B	65	40	80	450 475 475	132	160	260 270 270	-	100	70	240	190	47 45 45	-	-	50	-	14	-	121	122	290 295 295	-	-	10	-	43 50 53
	B-NM 40/20C/B-D/B B-NM 40/20A/A-AR/A-B/A	65	40	100	495 580	160	180	298 320	-	100	70	265	212	60 49	-	-	50	-	14	-	142	142	295 375	-	-	12	-	59,5-59 80,5-75
	2	B-NM 4025/C/C B-NM 4025/B/C B-NM 4025/A/C	65	40	100	635 685 710	192	225	377	12	125	95	320	250	-	216	20	65	69	14	12	175	175	174	298	258	-	6
B-NM 50/12F/B B-NM 50/12D/A B-NM 50/12A/B-S/B		65	50	100	470 495 495	132	160	260 270 270	-	100	70	240	190	47 45 45	-	-	50	-	14	-	122	137	290 295 295	-	-	10	-	44 52 54,5-54
B-NM 50/160A/B-B/B		65	50	100	580	160	180	320	-	100	70	265	212	49	-	-	50	-	14	-	126	140	375	-	-	12	-	80-74,5
2	B-NM 50/200B/C B-NM 50/200A/C B-NM 50/200S/C	65	50	100	695 745 769	192	200	377	32	100	70	265	212	-	216	20	50	69	14	12	140	153	234	298	258	-	6	123 132 154
	B-NM 5025/C/C B-NM 5025/B/C B-NM 5025/A/C	65	50	100	685 710 710	192	225	377	12	125	95	320	250	-	216	20	65	69	14	12	175	175	174	298	258	-	6	135 156 161
	B-NM 65/12E/A	80	65	100	500	160	180	298	-	125	95	280	212	60	-	-	65	-	14	-	130	154	300	-	-	12	-	57,3
1*	B-NM 65/125A/B-C/B	80	65	100	585	160	180	320	-	125	95	280	212	49	-	-	65	-	14	-	130	154	380	-	-	12	-	80,5-74,5
	B-NM 65/160D/B B-NM 65/160C/C	80	65	100	575 660	160	200	320 345	-	125	95	280	212	49 40	-	-	65	-	14	-	140	179	375 430	-	-	12	-	80,2 101
2	B-NM 65/160B/C B-NM 65/160A/C-AR	80	65	100	745 770	192	200	377	32	125	95	280	212	-	216	20	65	69	14	12	140	179	234	298	258	-	6	140 152
	B-NM 65/200B/C-C/C B-NM 65/200A/B	80	65	100	775 825	192	225	377 408	12 22	125	95	320	250	-	216 254	20	65	69 90	14	12 14	159 179	239 245	298 400	258 360	-	6	167-160 190	
	B-NM 65/250C/B	80	65	100	825	202	250	408	2	160	120	360	280	-	254	20	80	90	18	14	179	195	245	400	360	-	42*	210
1*	B-NM 80/160E/B B-NM 80/160D/C	100	80	125	605 685	180	225	340 365	-	125	95	320	250	60 50	-	-	65	-	14	-	153	181	375 430	-	-	12	-	89,4 109
	B-NM 80/160C/C B-NM 80/160B/C B-NM 80/160A/C	100	80	125	775 800 800	192	225	377	12	125	95	320	250	-	216	20	65	69	14	12	153	181	239	298	258	-	6	149 161 167

* Version without coupling guard

Dimensions and weights

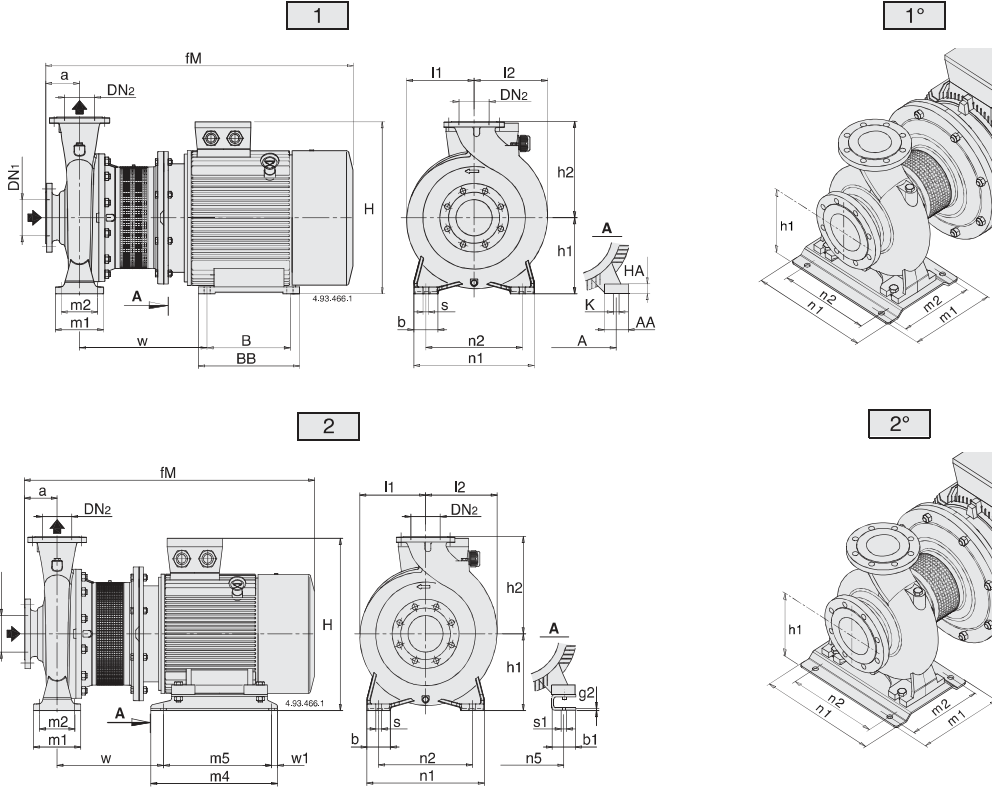

Picture	B-NMS	mm																												kg			
		DN1	DN2	a	fM	h1	h2	H	m1	m2	n1	n2	A	n5	w1	b	AA	b1	s	K	s1	l1	l2	w	BB	m4	B	m5	HA		g2		
2	B-NMS 65/250B/A	80	65	100	961	200	250	486	160	120	360	280	-	279	20	80	-	70	18	-	15	179	195	333	-	440	-	400	-	20	-	-	
1	B-NMS 65/250A/B	80	65	100	1009	200	250	515	160	120	360	280	318	-	-	80	70	-	18	19	-	200	200	406	355	-	305	-	25	-	-	353	
2	B-NMS 80/200B/A	100	80	125	936	180	250	387	125	95	345	280	-	254	20	65	-	60	14	-	15	175	194	331	-	350	-	310	-	5	-	-	
1	B-NMS 80/200A/A	100	80	125	986	180	250	466	125	95	345	280	279	-	-	65	65	-	14	15	-	170	194	394	328	-	279	-	20	-	-	266	
2	B-NMS 80/250E/A	100	80	125	936	200	280	407	160	120	400	315	-	254	20	80	-	60	18	-	15	191	210	331	-	394	-	354	-	6	-	-	
2	B-NMS 80/250D/A	100	80	125	986	200	280	486	160	120	400	315	-	279	20	80	-	70	18	-	15	191	212	333	-	440	-	400	-	20	-	-	287
1	B-NMS 80/250C/A	100	80	125	1034	200	280	515	160	120	400	315	318	-	-	80	70	-	18	19	-	200	210	406	355	-	305	-	25	-	-	-	
1°	B-NMS 80/250B/A	100	80	125	1129	225	280	563	298	258	410	315	356	-	-	-	-	18	19	-	225	225	445	361	-	311	-	34	-	-	-	-	
2°	B-NMS 80/250A/A	100	80	125	1198	280	280	690	260	220	410	315	-	406	25	-	-	100	18	-	24	275	275	443	-	500	-	450	-	8	-	-	-
2	B-NMS 100/200E/A	125	100	125	882	200	280	387	160	120	360	280	-	216	20	80	-	69	18	-	12	180	212	322	-	298	-	258	-	6	-	250	
2	B-NMS 100/200D/A	125	100	125	936	200	280	407	160	120	360	280	-	254	20	80	-	60	18	-	15	180	212	331	-	394	-	354	-	6	-	-	-
2	B-NMS 100/200C/A	125	100	128	1034	200	280	535	160	120	360	280	-	279	20	80	-	70	18	-	15	180	212	345	-	440	-	400	-	20	-	-	-
1	B-NMS 100/200B/A	125	100	125	1034	200	280	515	160	120	360	280	318	-	-	80	70	-	18	19	-	200	212	406	355	-	305	-	25	-	-	352	
1°	B-NMS 100/200A/A	125	100	125	1129	225	280	563	298	258	410	315	356	-	-	-	-	80	18	19	-	225	225	445	361	-	311	-	34	-	-	-	-
2°	B-NMS 100/250B/A	125	100	140	1213	280	280	690	260	220	410	315	-	440	25	-	-	100	18	-	24	275	275	443	-	500	-	450	-	8	-	-	-
1°	B-NMS 100/250A/A	125	100	140	1286	280	280	713	260	220	410	315	457	-	-	-	-	100	18	24	-	275	275	516	479	-	368	-	40	-	-	-	-

Flanges EN 1092-2

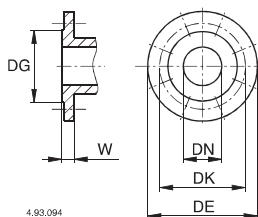

mm						
DN	DG	DK	DE	Holes		W
				N°	Ø	
32	76	100	140	4	19	18
40	84	110	150	4	19	18
50	99	125	165	4	19	20
65	118	145	185	4	19	20
80	132	160	200	8	19	22
100	156	180	220	8	19	24
125	184	210	250	8	19	24

Features

Cutting edge hydraulics

The geometry of the impeller and the pump casing are optimized to achieve maximum efficiency and the best suction capability.

Flexible

The option to choose between cast iron and bronze materials for the hydraulic parts in contact with the pumped liquid allows NM series pumps to be selected for use with different types of liquids.

Compact Design

The compact design allows for easy installation even in confined spaces.

Exclusive design

An innovative, patented guard prevents contact with rotating parts, proving protection to the end user whilst allowing for inspection of the mechanical seal.

Reliable

The bearing and shaft are designed to ensure the reduction of the stress, providing high reliability under all operating conditions.

NM

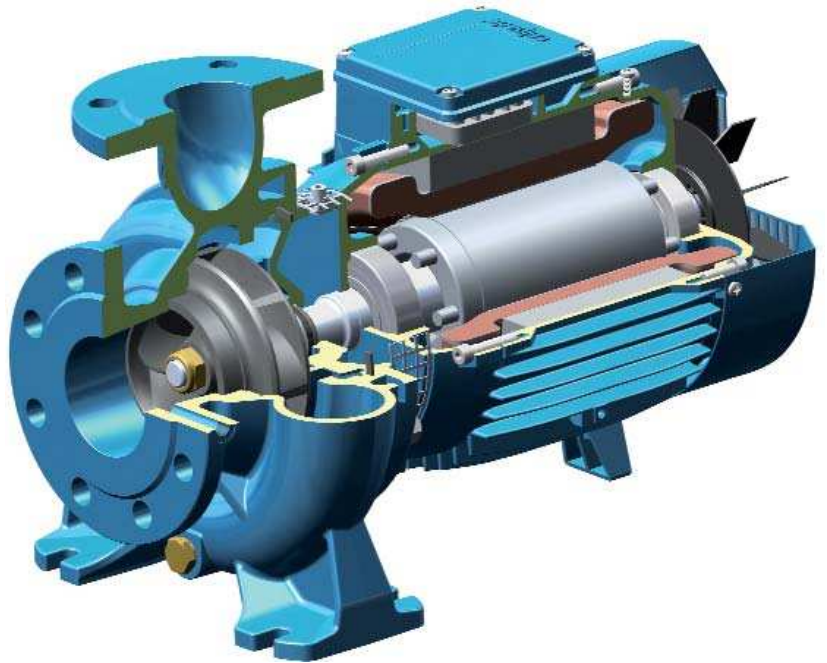

Cutting edge hydraulics

The geometry of the impeller and the pump casing are optimized to achieve maximum efficiency and the best suction capability.

Flexible

The option to choose between cast iron and bronze materials for the hydraulic parts in contact with the pumped liquid allows NMS series pumps to be selected for use with different types of liquids.

New lantern bracket construction

The lantern brackets incorporate a thrust bearing on the hydraulic side which guarantees the elimination of additional loads on the motor bearings. The flange is sized to be used with standard motors B35.

Exclusive design

An innovative, patented guard prevents contact with rotating parts, proving protection to the end user whilst allowing for inspection of the mechanical seal.

Simplified motor maintenance

The presence of the thrust bearing on the hydraulic side makes it easier to remove the motor, facilitating maintenance operations and eliminating the risks of damage to the hydraulic parts.

NMS

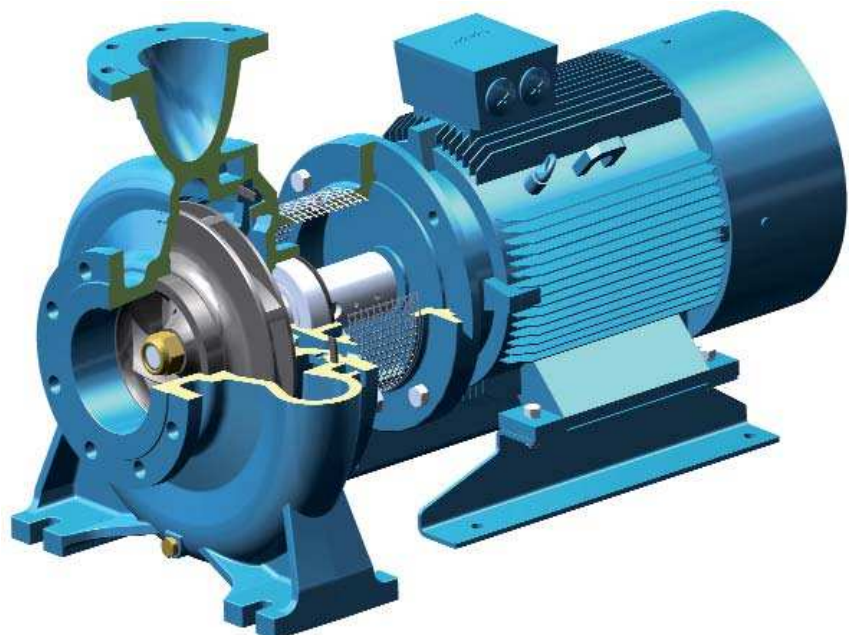

NM4, NMS4

Close Coupled Centrifugal Pumps
n ≈ 1450 rpm



Construction

Close-coupled centrifugal pumps; electric motor with extended shaft directly connected to the pump up to 15 kW, new bracket construction for standard motors (Stub-shaft construction) from 18,5 to 75 kW with integrated thrust bearing. Pump casing with axial suction and radial delivery on top, main dimensions and performance according to EN 733 with additional sizes for completion. NM(S)4: version with pump casing and lantern bracket in cast iron. B-NM(S)4: version with pump casing and lantern bracket/casing cover in bronze. (the pumps are supplied fully painted).

Connections

Sizes	Connections
NM4 25/...	Threaded ports ISO 228
from NM4 32/.. to NMS4 150/..	Flanges according to PN 10, EN 1092-2

Counter-flanges (on request)

Sizes	Flanges
from NM4 32/.. to NM4 50/..	Screwed flanges EN 1092-1, PN 16
from NM4 32/.. to NMS4 150/..	Flanges for welding EN 1092-1, PN 10

Version with frequency converter (on request)

Applications

For clean liquids without abrasives, which are non-aggressive for the pump materials (contents of solids up to 0,2%). For water supply. For heating, air conditioning, cooling and circulation plants. For civil and industrial applications. When low noise operating is required. For irrigation.

Operating conditions

Liquid temperature from -10 °C to +90 °C.
Ambient temperature up to 40 °C.
Total suction lift up to 7 m.
Maximum permissible working pressure up to 10 bar (16 bar for NM4 40/16,20; NM4 50/16; N4M 65/16,20,25; NM4 80/16).
Continuous duty.

Motor

4-pole induction motor, 50 Hz (n ≈ 1450 rpm).
NM4, NMS4: three-phase 230/400 V ± 10% up to 3 kW; 400/690 V ± 10% from 4 to 75 kW.
Insulation class F. Protection IP 54 (IP 55 for NMS4).
Motor suitable for operation with frequency converter from 0,75 kW.
Classification scheme IE3 for three-phase motors from 0,75 kW.
Constructed in accordance with: EN 60034-1; EN 60034-30-1.

Special features on request

- Other voltages. - Frequency 60 Hz (as per 60 Hz data sheet).
- Protection IP 55. - Special mechanical seal.
- Higher or lower liquid or ambient temperatures.
- Motor suitable for operation with frequency converter up to 0,55 kW.

The electropumps NM4, B-NM4, NMS4, B-NMS4 series comply with the European Regulation no. 547/2012.

Materiali

Components	NM4, NMS4	B-NM4, B-NMS4
Pump casing	Cast iron	Bronze
Lantern bracket NM4	GJL 200 EN 1561	G-Cu Sn 10 EN 1982
Casing cover for NMS4		
Lantern bracket NMS4	Cast iron GJL 200 EN 1561	
Impeller	Cast iron	Bronze
	GJL 200 EN 1561	G-Cu Sn 10 EN 1982
	Brass P- Cu Zn 40 Pb 2 UNI 5705	
	For NM4 25/125 - 25/160 - 25/200 - NM4 32/16 - 32/20 - 40/20	
Shaft	AISI 303 up to 1,1 kW	Cr Ni Mo steel
	AISI 430 from 1,5 kW to 75 kW	AISI 316
Mechanical seal	Carbon - Ceramic - NBR	
Counter-flanges	Steel Fe 430B UNI 7070	

Coverage chart n ≈ 1450 rpm

